

Numero Verde  
**800020343**



dnd è un marchio di FMN Martinelli S.p.A.  
località Piani di Mura 2  
25070 Casto (BS) Italia  
Tel. +39-0365-899113 r.a. Fax +39-0365-899118

COMPANY  
WITH QUALITY SYSTEM  
CERTIFIED BY DNV  
**ISO 9001/2000**

made in italy



CATALOGO GENERALE DND ED. 2008 REV. 00

DI MANO IN MANO

DI MANO IN MANO



[www.dndmaniglie.it](http://www.dndmaniglie.it)

[www.dndmaniglie.it](http://www.dndmaniglie.it)



INDICE CATALOGO - CATALOGUE INDEX

<i>Maniglie - Door handles</i>	ART	112
	BLIP	68
	BLIP COLORS	70
	DOLCE	74
	DOLCE 02	76
	EDRA	42
	EDRA 02	44
	EGO	50
	FLUKE	56
	FLUKE 02	58
	FLUKE COLOR	60
	FLUO'	108
	GO	110
	HALLEY	106
	HAVANA	72
	LINEAR	102
	LINEAR 02	104
	LOGO	96
	LOGO-B	98
	LOGO 02	100
	LUXURY	38
	LUXURY 02	40
	MOVIDA	46
	MOVIDA-B	48
	SIKE	62
	SIKE 02	64
	SIKE COLOR	66
	TWIST	52
	TWIST 02	54
	VITA	78
	VITA-B	80
	VITA-C	82
	VITA-D	84
	VITA LEGNO	86
	VITA 02	88
	VITA S	90
	ZEN	92
	ZEN LEGNO	94

Maniglioni	ART	124
<i>Pull handles</i>	ART	126
	GO	128
	LINEAR	120
	LINEAR	122
	LOGO	116
	LOGO-B	118

<i>Pomoli - Knobs</i>	ART	132
	FLUO'	136
	GO	134

<i>Portabiti</i>	ALGA	148
<i>Coat hangers</i>	ALGA	150
	LOTO	142
	MEDUSA	144
	MEDUSA	146
	MOBY	140

<i>Articoli vari</i>	BOCCHETTE	158
<i>Miscellaneous</i>	<i>Escutcheons</i>	
	NOTTOLINI	154
	<i>Turns &amp; releases</i>	
	PLACCHE	159
	<i>Plates</i>	
	ROSETTE	156
	<i>Roses</i>	

	ESPOSITORI	162
	<i>Displays</i>	
	CONFEZIONI	160
	<i>Packaging</i>	

<i>Sistemi di montaggio</i>	MANIGLIE	168
<i>Assembling systems</i>	<i>Door handles</i>	
	MANIGLIONI	173
	<i>Pull handles</i>	
	POMOLI	172
	<i>Door knobs</i>	
	PORTABITI	174
	<i>Coat hangers</i>	



DI MANO IN MANO

[www.dndmaniglie.it](http://www.dndmaniglie.it)

Numero Verde  
**800020343**





## INDICE GENERALE - INDEX

Introduzione - <i>Introduction</i>	5
Tradizione - <i>Tradition</i>	6
Corporate - <i>Corporate</i>	9
Qualità - <i>Quality</i>	12
Martinelli nel mondo - <i>Martinelli in the world</i>	18
Designer - <i>Designers</i>	21
Condizioni di vendita - <i>Sale terms</i>	28
Finiture - <i>Finishes</i>	30
Indice catalogo - <i>Catalogue index</i>	36
Maniglie - <i>Door handles</i>	37
Maniglioni - <i>Pull handles</i>	115
Pomoli - <i>Knobs</i>	131
Portabiti - <i>Coat hangers</i>	139
Articoli vari - <i>Miscellaneous</i>	153
Sistemi di montaggio - <i>Assembling systems</i>	167



1968 - 2008



**dnd**® è un marchio di FMN Martinelli S.p.A.

Nato nel 1998 in collaborazione con il designer Mauro Ronchi, la divisione **dnd**® diffusione nuovo design si impone da subito come marchio giovane, innovativo capace di dare nuovo impulso all'azienda e di indicare direzioni inedite in termini di ricerca e design, stile e cultura.

Attraverso l'apporto creativo di designer come Karim Rashid, Mauro Ronchi e lo studio Hot Lab, **dnd**® reinterpreta la maniglia quale complemento d'arredo, fortemente connotata per funzionalità, ergonomicità ed estetica.

Tutte le maniglie (tranne il modello BLIP prodotto in alluminio) e la gamma di accessori **dnd**® sono realizzati in ottone stampato a caldo, procedimento in grado di garantire un livello di qualità superiore in termini di integrità del materiale, tolleranze delle dimensioni, finiture in superficie.

L'ottima qualità del prodotto è inoltre garantita dalle rifiniture eseguite manualmente da artigiani esperti che rendono ogni pezzo di grande valore.

**dnd**® maniglie, maniglioni, appendini, pomoli un perfetto connubio tra valori della tradizione e avanguardia delle forme.

FMN Martinelli S.p.A., guidata oggi dalla "seconda generazione Martinelli" ha mantenuto inalterata la garanzia di un prodotto di qualità con una tradizione e una storia, supportando l'attività produttiva con accresciute capacità manageriali, tecnologiche e creative.

Grazie a questa filosofia che si ispira a valori quali la creatività, la qualità, la tecnologia e, non meno importante, la comunicazione, il Gruppo FMN Martinelli da 40 anni realizza prodotti altamente affidabili nel tempo.

FMN Martinelli creando maniglie come continuo oggetto della sua storia è protagonista del design con la divisione **dnd**®.

**dnd**® is an FMN Martinelli S.p.A. brand.

*Born in 1998 in collaboration with the designer Mauro Ronchi, the brand **dnd**® diffusione nuovo design (diffusion of new design) has been an immediate success as a young brand, innovative and able giving a new stimulus to the Company as well as leading to original solutions in terms of research and design, style and culture.*

*Through the creative contribution of designers such as Karim Rashid, Mauro Ronchi and the Hot Lab Studio, **dnd**® reinterprets the door handle as a furnishing complement, strongly characterized by functionality, ergonomic and aesthetic.*

*All the door handles (except for BLIP model realized in Aluminium), and the accessories **dnd**® are in brass and are hot stamping produced, a manufacturing process which is able to guarantee a superior quality level in terms of material integrity, dimensions tolerance, surface finishing. The excellent product quality is guaranteed also by the finishing made by expert artisans which make each piece of a great value.*

**dnd**® door handles, pull handles, coat hangers, door knobs: a perfect mix between traditional worth and avant-garde shapes.

*FMN Martinelli S.p.A., which is now lead by the "second Martinelli generation" is maintaining the guarantee for a quality product unchanged through the experience and tradition supporting the production activity with improved managing, technological and creative capacities.*

*Thanks to its philosophy which takes inspiration from values such as creativity, quality, technology and not less important, communication, the Martinelli Group has been realizing reliable products for 40 years.*

*FMN Martinelli S.p.A. creating door handles as a continuous part of its history is a protagonist of design with the division **dnd**®.*

marchi registrati



*FMN Martinelli was established in 1968 in the Valle Sabbia, a region of Northern Italy which traditionally maintains its expertise and passion for brass foundry products, it's in our genes. These same values are still reflected today in our current mission statement for the Company. Exhaustive research and continually striving to enhance the quality of our products is the basis for every decision; starting with detailed planning and the careful selection of quality raw materials, through all the working phases, bringing together the benefits of expert Human Resources, skilful communication and efficient distribution of products which has contributed to the popularity and trust we enjoy from our International Customers who all share and appreciate our values. FMN Martinelli presents its own unique image and work ethic in the deep conviction that tradition and innovation are the essential components to continued development and maintaining a synergy with our valued Customers.*

*The tradition, starting with the timeless qualities of brass, worked and forged in various forms that over time now reflects both the classical and modern. Our production plant is located on a 10.000 square meters site, and services a hard working organization where attention to efficiency and safety have combined to create production lines of door handles where both the classic and contemporary merge. Our innovation expresses itself magnificently with the "dnd" line (diffusion of new design), an internal division born as a natural answer to the demands of a market in constant evolution. "dnd" is indicative of a new direction and our commitment to design and quality, style and culture concerns. The new "dnd" catalogue that we are proud to present, is the result of a laboratory of ideas formed by passionate and tenacious persons whose aim is to create and produce new objects representing the taste and personality of those who love fine things.*



La FMN Martinelli nasce nel 1968 in un territorio, la Valle Sabbia, che ha nel proprio dna la passione e la tradizione del lavoro, valori che l'azienda assume come propria missione. Un forte senso della qualità del proprio prodotto è alla base di ogni decisione; partendo dalla progettazione e dalla scelta dei materiali, attraversando tutte le fasi di lavorazione, fino alla valorizzazione delle risorse umane, alla comunicazione, e alla diffusione di prodotti che si sono guadagnati riconoscibilità e fiducia da parte di una clientela internazionale che condivide i nostri stessi valori. È con la profonda convinzione che la tradizione e l'innovazione siano valori forti, capaci di creare sinergia e sviluppo, che FMN Martinelli presenta e comunica la propria immagine e il proprio lavoro. La tradizione parte da un materiale antico come l'ottone, lavorato e forgiato in forme che il tempo ha reso classiche e moderne. Impianti produttivi posti su un'area di 10.000 mq, al servizio di un'organizzazione del lavoro attenta a criteri di efficienza e sicurezza, realizzano linee di maniglie dove gusto classico e contemporaneo s'incontrano.

L'innovazione si esprime nella linea "dnd" diffusione nuovo design", divisione interna che, nata come naturale risposta ad un mercato in costante evoluzione, vuole indicare nuove direzioni in termini di design, qualità, stile e cultura. Il nuovo catalogo dnd che presentiamo con orgoglio, è frutto di un laboratorio di idee fatto di persone che con passione e tenacia si pongono l'obiettivo di creare e produrre nuovi oggetti che rappresentino il gusto e la personalità di chi ama le cose belle.



**dnd**  
diffusione nuovo design

D I M A N O I N M A N O

**martinelli**  
HANDLES WITH CARE

L'EVOLUZIONE  
DEI LOGO NELLA STORIA  
LOGO EVOLUTION  
IN ITS HISTORY



1968



1978



1982



1992



1995



2007



1998



2007



## LA NUOVA SFIDA

**Riteniamo l'azienda creatrice di valori, oltre che di prodotti.**

Nel marketing comunicazionale ogni azienda è sempre più percepita come realtà che propone valori oltre che prodotti, comunicati e fruiti come elementi di identità e posizionamento. Questi valori "immateriali", ma molto concreti, formano la corporate identity.

**La creatività risponde a tre elementi coordinati.**

- identificazione coerente: l'immagine dell'azienda deve presentarsi in maniera comprensibile, distinguibile: Le differenti parti attive che lo compongono devono essere correlate tra loro, in modo da restituire sempre un quadro generale.

- riverberazione segnica: il brand deve riuscire a esprimere, anche in territori applicativi diversificati, la sua missione e i suoi obiettivi, tramite l'uso di segni condivisi

- posizionamento: il brand, tramite un linguaggio visuale appropriato, deve posizionarsi sul mercato e riuscire a distinguere se stesso e i suoi prodotti dalle imprese concorrenti

**I valori di riferimento.**

- attenzione al design (ma più in generale agli stili contemporanei)
- capacità di unire estetica e funzionalità
- innovazione senza rinunciare alla tradizione
- internazionalità, pur ribadendo l'originale made in Italy

**dnd**® è il nuovo marchio di fabbrica della FMN Martinelli S.p.A. Nato nel 1998 allo scopo di dare un esito produttivo a un aspetto della nostra attività che è spesso solo sulla carta o allo stadio di prototipi: il desiderio di portare avanti ricerche con un alto grado di innovazione formale, costruttiva e funzionale, anche di tipo sperimentale, libere dai limiti normalmente imposte dalle produzioni industriali di grande serie.

Desideriamo offrire ad un pubblico attento e culturalmente curioso un ampio spettro di proposte con la ricerca condotta di alcune delle personalità più interessanti dell'attuale panorama del disegno industriale.

Non antagonista, ma complementare alla produzione con il marchio "martinelli" (che continua la strada che è la propria degli oggetti di grande serie per il vasto pubblico, documentata dall'annuario della produzione martinelli), proveniente dalla stessa fabbrica di Casto e dalle sue abili maestranze. la nuova produzione con il marchio "dnd" si ritaglia dunque nuovi spazi nel panorama sempre più articolato e complesso del mercato contemporaneo.

## THE NEW CHALLENGE

**We consider the Company creator of values, not just products.**

*In communication marketing, each Company is perceived more and more as an entity offering values, in addition to products, information and benefits, as tools for defining its identity and position. These "immaterial" but very tangible values are what build the corporate identity.*

**Creativity provides the answer to three interlinked elements**

- *Consistent identification: the Company image needs to be presented in a way which is comprehensible and unique. Its various active components need to be correlated and capable of presenting a general view.*

- *Graphic representation: the brand needs to clearly express the Company's mission and objectives, by means of widely understood symbols and within varied fields of application.*

- *Positioning: the use of an appropriate visual language needs to be implemented, ensuring that the brand finds its proper positioning within the market and separates itself and the products it represents from competing organisations.*

**The reference values**

- *attention to design (and, in more general terms, to contemporary styles)*
- *ability to combine aesthetics to functionality*
- *innovation and research without renouncing to the tradition*
- *internationality, whilst emphasizing the "Made in Italy" concept*

**dnd**® is a new brand name of FMN Martinelli S.p.A. Born in 1998 to give a production answer to our activity specifics which are often only on paper or at the stage of prototypes: the desire of bringing forward researches with a very high degree of formal innovation, constructive and functional, even experimental, free from the limits normally given by the industrial productions of big series.

*We wish to offer to an attentive and culturally curious public a wide spectrum of proposals made by some of the most interesting personalities in the current Industrial Design panorama.*

*Not antagonistic, but complementary with the "martinelli" brand (which continues its own way for the objects directed to the wide public, showed in the Martinelli catalogue) the new production with the brand "dnd", originated by the same Factory at Casto and capable craftsmen, has his own and new scopes in the more and more complex and articulate panorama of the contemporary market.*







## QUALITÀ

Il 31 dicembre 2001 l'Azienda ha ottenuto la certificazione del proprio sistema di qualità in base alle normative UNI EN ISO 9002:1994. Il sistema qualità in seguito è stato integrato con la progettazione interna ed il 17/07/2003 l'Azienda ha ottenuto la certificazione in base alle nuove normative UNI EN ISO 9001:2000. La certificazione è stata rilasciata da DNV – DET NORSKE VERITAS tra i più prestigiosi enti di certificazione internazionali.

Certificato No. CERT-09918-2001-AQ-MIL-SINCERT

Il sistema di gestione della Qualità aziendale secondo le norme UNI EN ISO 9001:2000 consente di controllare costantemente lo standard qualitativo di ogni processo produttivo, di selezionare i fornitori, di monitorare la qualità dei servizi rivolti alla clientela.

### PROGETTAZIONE.

L'ufficio tecnico dell'Azienda con la collaborazione frequente di designer esterni pone la massima attenzione alla realizzazione dei nuovi progetti al fine di ottenere prodotti funzionali associati alle attuali esigenze estetiche.

### FORMAZIONE DELLE RISORSE UMANE.

L'azienda investe numerose risorse nell'addestramento e nella formazione delle maestranze e del personale addetto, con l'intento di creare una sempre maggiore consapevolezza e partecipazione che garantiscano un continuo miglioramento della qualità aziendale.

### AMBIENTE DI LAVORO

Particolare attenzione viene posta alla tutela della salute negli ambienti di lavoro.

Periodicamente vengono effettuati indagini che permettono di controllare i livelli fonometrici e la salubrità dei locali.

### PRODUZIONE

I vari processi produttivi svolti con l'utilizzo di macchinari e tecnologie all'avanguardia sono continuamente monitorati. I prodotti subiscono un controllo qualitativo in ogni fase di lavorazione ed un collaudo finale in fase di assemblaggio.

### MONITORAGGIO

Periodicamente viene analizzato il processo aziendale con particolare attenzione alle non conformità riscontrate.

### SODDISFAZIONE DEL CLIENTE

Una continua e costante attenzione è tesa ad ottenere la massima soddisfazione del Cliente che trova assistenza e disponibilità in tutte le fasi del rapporto.

## QUALITY

At December 31st. 2001 FMN Martinelli SpA obtained the Certification of its own Quality System in conformity with UNI EN ISO 9002:1994 specifications. The Company Quality System has then been supplemented by internal planning and at July 17th. 2003 our Factory obtained the Certification in accordance with the UNI EN ISO 9001:2000 new specifications.

The Certification has been issued by DNV – DET NORSKE VERITAS one of the most prestigious Corporations for International Certification. Certificate No. CERT-09918-2001-AQ-MIL-SINCERT

The Company Quality System in conformity with the UNI EN ISO 9001:2000 specifications allows us to constantly examine the quality standard during each production process, to select suppliers and monitor the quality of services offered to our customers.

### DEVELOPMENT

The Technical Department of FMN Martinelli SpA, supported by frequent co-operation with external Designers, gives maximum attention to the realization of new projects which are both functional whilst at the same time corresponding to current aesthetic requirements.

### HUMAN RESOURCES

FMN Martinelli SpA invests large resources to ensure that there is continued improvement and awareness within the Company.

### WORKING ENVIRONMENT

Particular attention is given to the health and safety aspects within the working environment.

The Company carry out periodical investigations which allow us to control the phonometry level as well as the healthiness of the working environment.

### PRODUCTION

The various production phases made by the utilization of machinery and avant-garde technology are under continuous monitoring. The quality of the products is inspected during all the manufacturing phases. The final testing for approval is made during the assembling phase.

### MONITORING

The Company Quality System has periodical investigations with particular attention paid to the non-conformities we've registered.

### CUSTOMER SATISFACTION

Continuous and constant attention is paid to ensure maximum Customer satisfaction.

Assistance and willingness to help is guaranteed to the Customer during all phases of the business relationship.

Q U A L I T A '





**martinelli**<sup>®</sup>  
HANDLES WITH CARE

**dnd**  
diffusione nuovo design

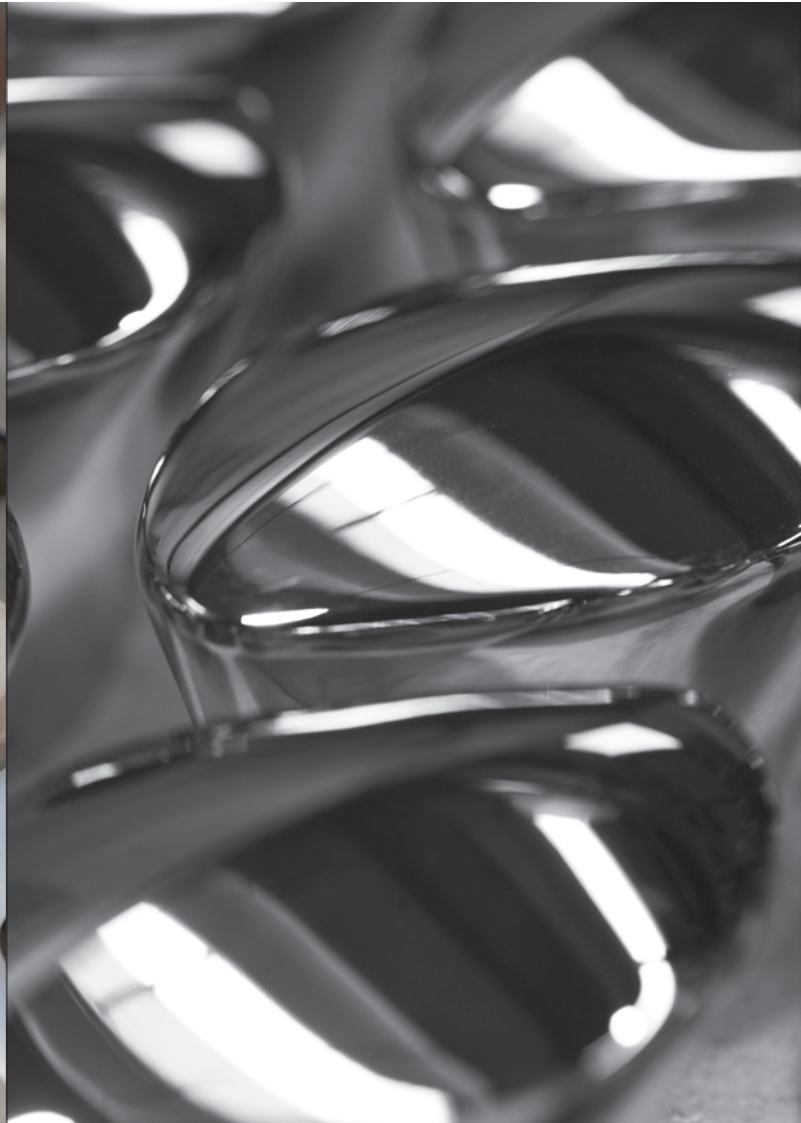



k n o w - h o w

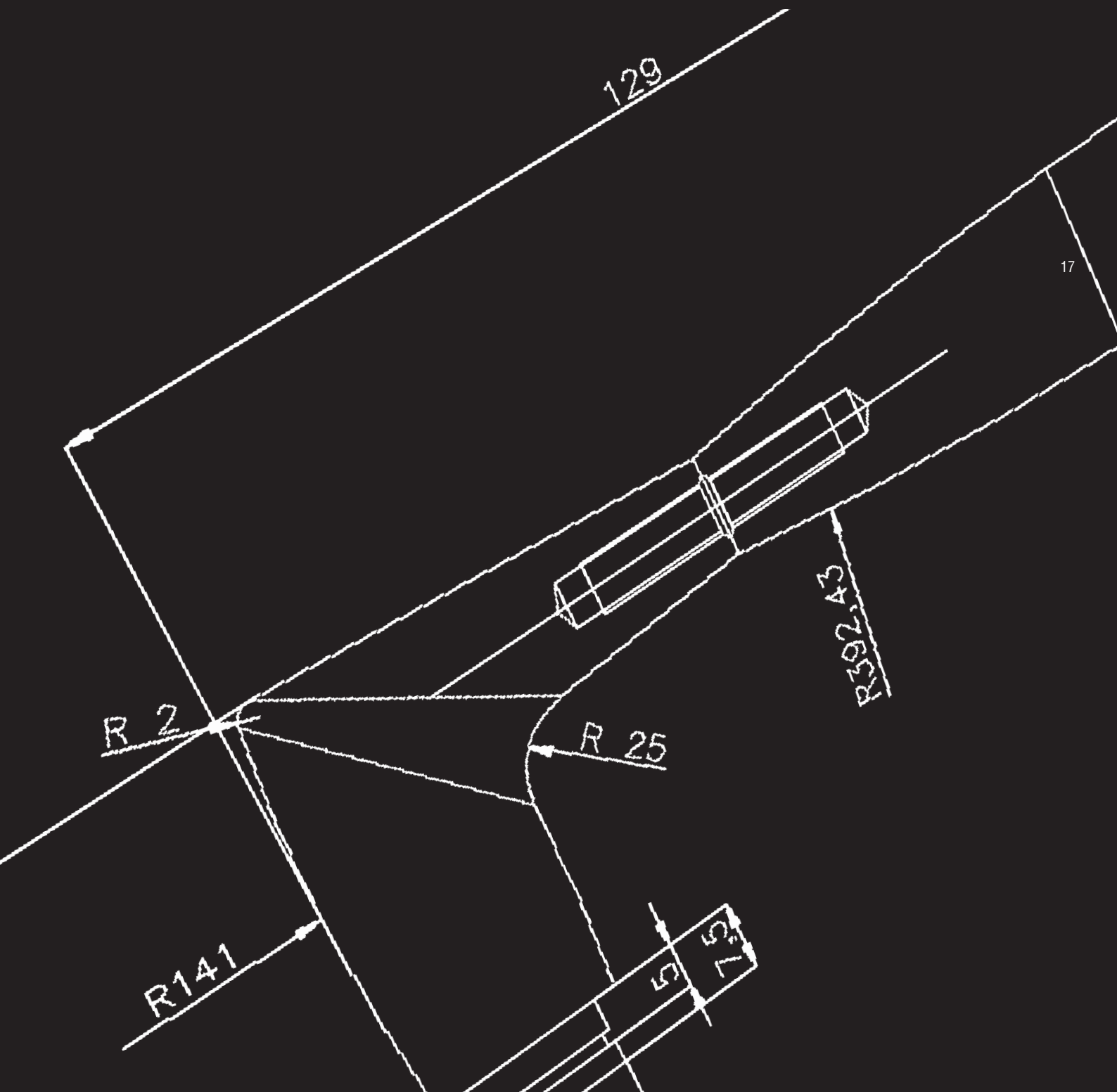

- ALGERIA
- ARABIA SAUDITA
- ARMENIA
- AUSTRALIA
- AUSTRIA
- AZERBAIJAN
- BAHRAIN

- BELGIO
- BOSNIA Y HERZEGOVINA
- BRASILE
- BULGARIA
- CANADA
- CAPO VERDE
- CILE
- CINA
- CIPRO
- COREA
- EGYPT

- ESTONIA
- FINLANDIA
- FRANCIA
- GEORGIA
- GERMANIA
- GIAPPONE
- GIORDANIA
- GRAN BRETAGNA
- GRECIA
- HONG KONG
- INDIA
- INDONESIA
- IRAN
- IRLANDA
- ISLANDA
- ISRAELE
- ITALIA
- KAZAKHSTAN
- KUWAIT.
- LIBANO
- LIBIA
- LITUANIA
- LUSSEMBURGO
- MALDIVE
- MALTA
- MAROCCO
- MAURITIUS
- NIGERIA
- NORVEGIA
- NUOVA ZELANDA
- OLANDA
- PAKISTAN
- POLONIA

- PORTOGALLO
- REPUBBLICA CECA
- REPUBBLICA S.MARINO
- REPUBBLICA SLOVACCA
- REPUBLIC OF MOLDOVA
- ROMANIA
- RUSSIA
- SERBIA
- SINGAPORE
- SIRIA
- SLOVENIA
- SPAGNA
- SRI LANKA
- SUD AFRICA
- SULT. OF OMAN
- SVEZIA
- SVIZZERA
- TAIWAN
- U.A.E.
- U.S.A.
- UKRAINA
- UNGHERIA
- VIETNAM
- YEMEN
- YUGOSLAVIA

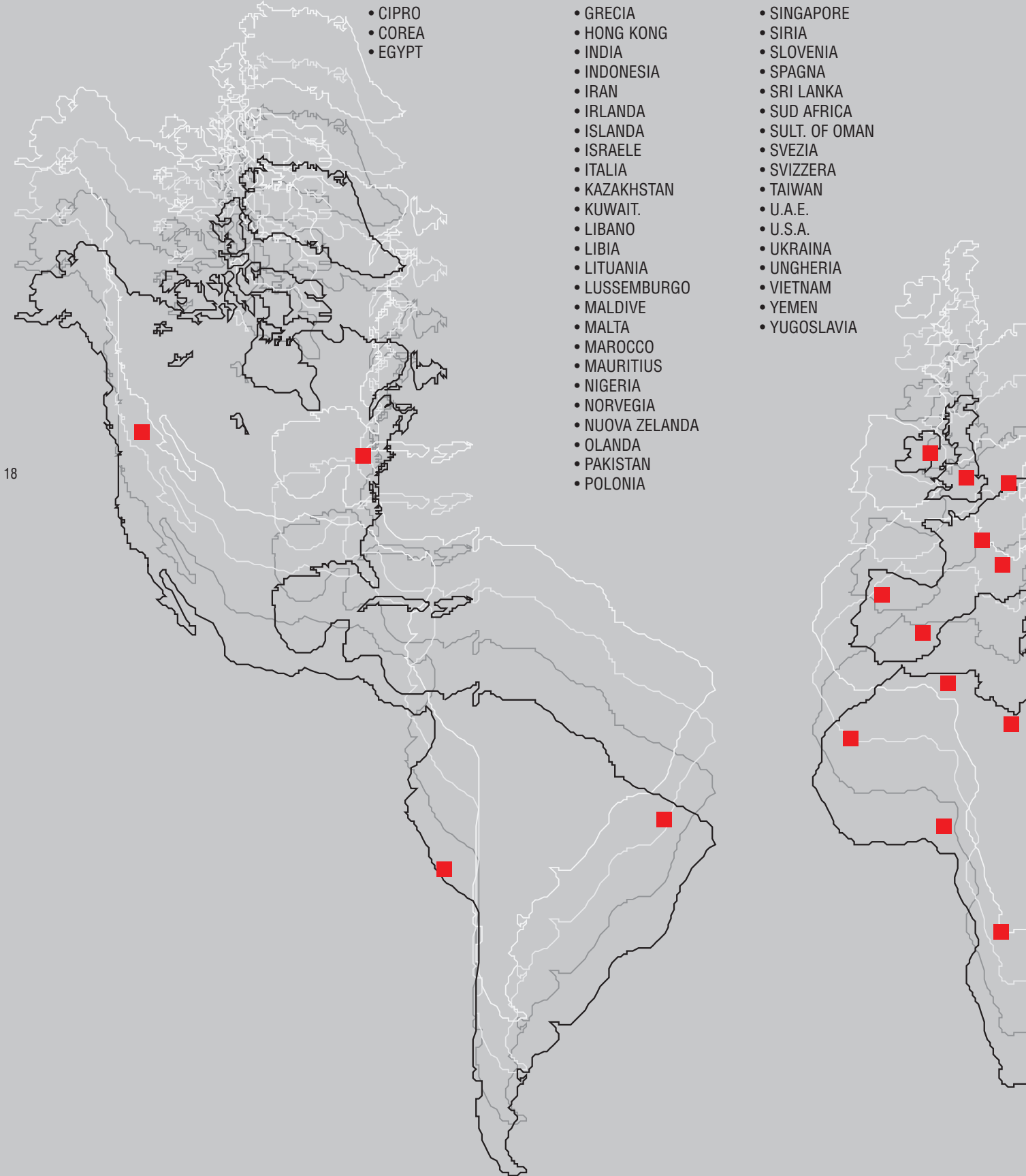





**dnd**® è l'evoluzione della ricerca, la filosofia sta nello studio e sperimentazione sempre proiettata al futuro che si rivolge principalmente al design nel suo significato più completo, per arrivare alla difficile sintesi tra tecnologia e progetto, tra economicità e risposte ad una esigenza sociale, anche nel settore della maniglia. Ricerca e accostamento di nuovi materiali, ricerca sulla lavorazione e cura del particolare.

**dnd**® is the search evolution, its philosophy is the studying and the experimentation projected into the future and mainly orientated towards the design in its complete meaning, between economic character and response to a social requirement, also in the door handle field. Search and matching of new materials, search of the working and care for the detail.

IL DESIGN

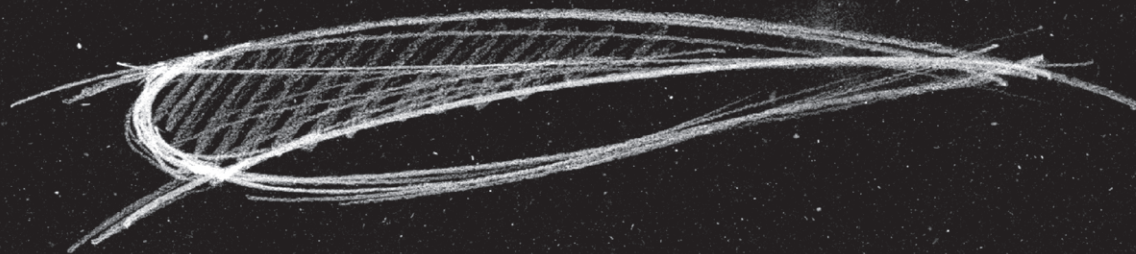

COME



21

SPERIMENTAZIONE

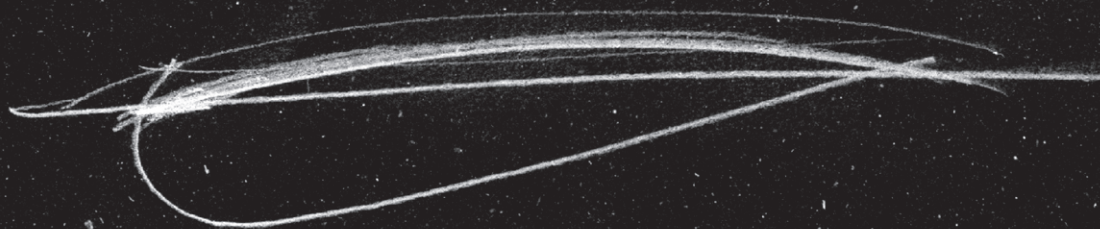

RICERCA

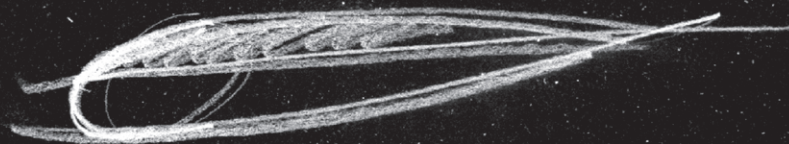



Front





Karim Rashid

Voglio cambiare il mondo

Karim Rashid è uno dei designer attualmente più conosciuti e prolifici nel mondo.

Già una superstar fra gli aficionados del designer, è ora sul punto di essere una celebrità casalinga (famigliare)

Con una carriera iniziata a diciannove anni Karim Rashid, ora quarantenne, è il creatore di più di 500 design di prodotti, che spaziano dall'attaccapanni alle bucalettere, dal packaging di profumi all'illuminazione, dalle stoviglie all'alta moda.

Il suo porta rifiuti Garbo è divenuto un'icona del design e ne sono stati venduti più di due milioni.

Il suo straordinario successo commerciale è stato rispecchiato dall'acclamazione critica e il suo lavoro può essere trovato nelle collezioni di musei di tutto il mondo, incluso il Museum of Modern Art, il Museum of Modern Art di San Francisco ed il Museum of Decorative Arts di Montreal.

*"I Want to Change the world..."*

*Karim Rashid is one of the best-known and most prolific designers at work in the world today.*

*Already a superstar among design aficionados, he is now on the brink of household-name celebrity.*

*With a career that began at the age of nineteen, Rashid is now forty and the creator of more than five hundred product designs, ranging from coat racks to letterboxes, perfume packaging to lighting, tableware to high fashion.*

*His Garbo rubbish-bin has become a design icon, and more than two million have been sold. His extraordinary commercial success has been mirrored by critical acclaim, and his work can be found in museum collections worldwide, including The Museum of Modern Art, the San Francisco Museum of Modern Art and The Montreal Museum of Decorative Arts*

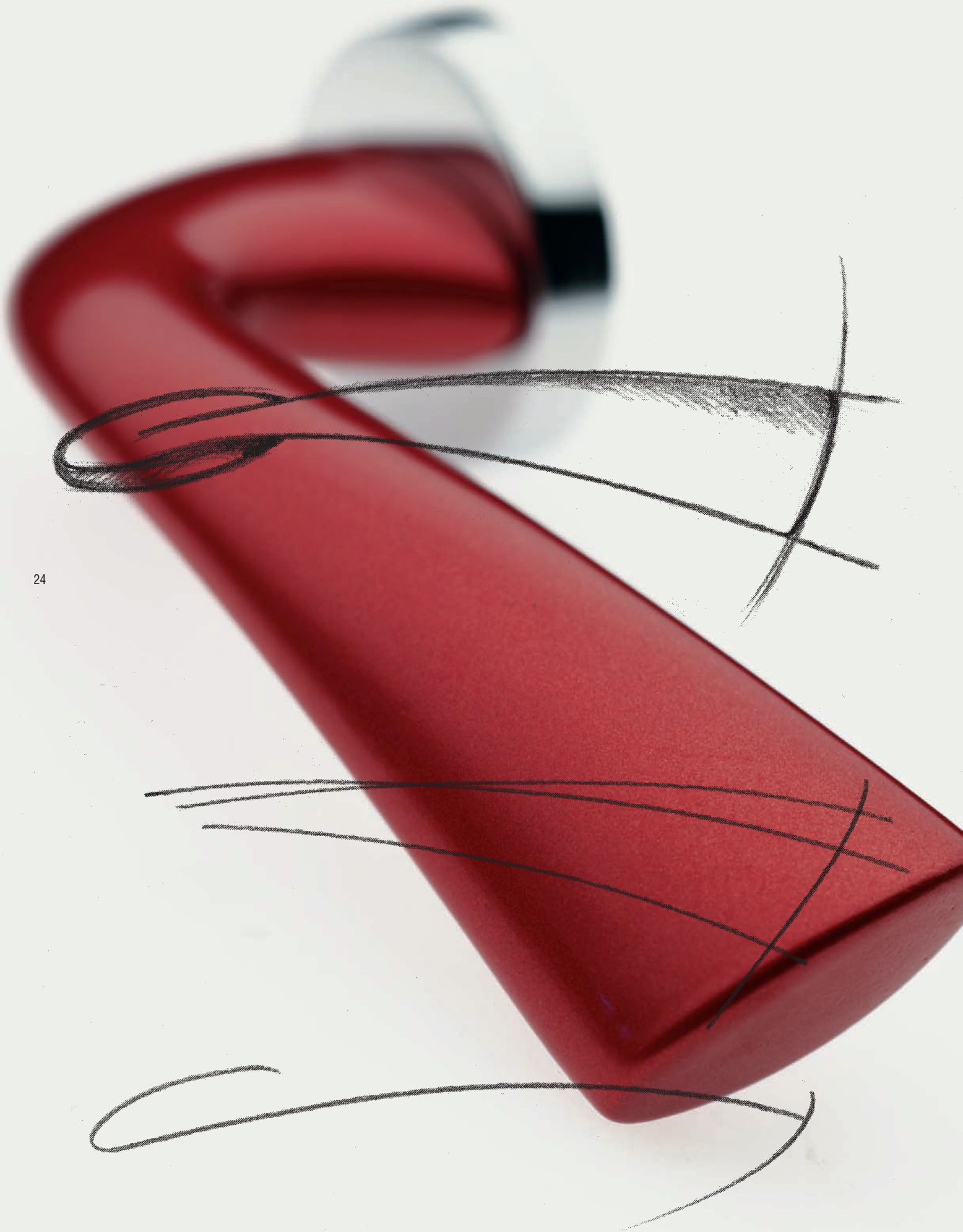

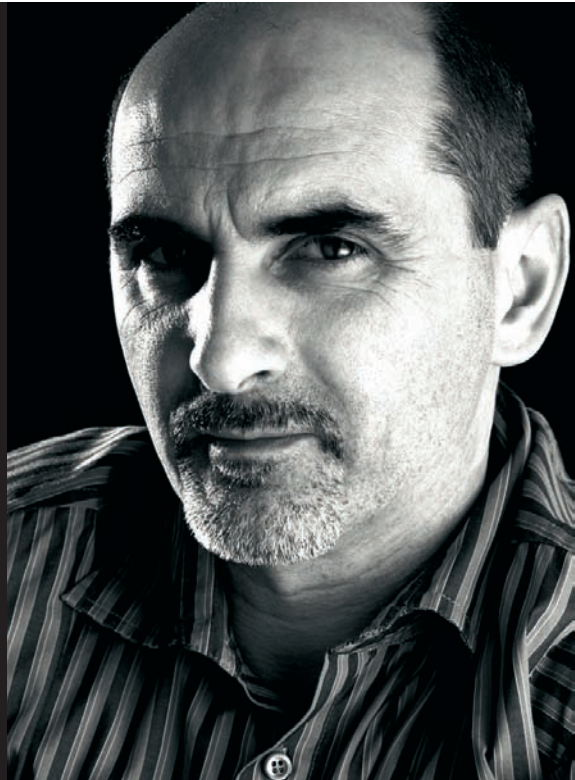

Mauro Ronchi

(1973-1975)

Diploma di maestro d'Arte presso l'istituto superiore ISAG)

(1976-1977)

Diploma di maturità d'Arte Applicata presso l'istituto superiore ISAG)

(1978-1982)

laureato all' ISIA di Urbino

Vincitore della borsa di studio del Rotary di Urbino per gli anni dal '78 al '82.

(1983-1984)

Socio fondatore in provincia di Trento dello studio Visual Design con lo scopo di ideare e promuovere progetti in vari settori dalla grafica, al design, all'arredamento.

(1984-1986)

Art director presso agenzia pubblicitaria in Brescia

(1986)

Fonda a Brescia lo studio Leadergrafica dove segue l'immagine aziendale e di prodotto per aziende, istituzioni pubbliche e privati.

(1993)

Si trasferisce in provincia riprendendo il nominativo originale di Visual.

(1996 al 2000)

Socio ACPI (associazione consulenti pubblicitari Italiani). Socio e fondatore nel 2000 dello studio Artex in provincia di Trento laboratorio di idee nella progettazione grafica e stampa su tessuto in grande formato. Attualmente Socio professionista ADI (associazione disegno industriale)

Vive e lavora a Villanuova Sul Clisi (BS)

presso il proprio studio Visual, una nuova struttura di 350 mq. in stile minimalista concepita con grandi spazi liberi.

Il lavoro di Ronchi spazia in vari settori: industrial design, grafica, architettura d'interni, arredamento, oggettistica per la casa, illuminazione, allestimenti, eventi.

(1973-1975)

Art Master Diploma at the ISAG State Institute.

(1976-1977)

High School Diploma in Applied Art at ISAG.

(1978-1982)

Art degree at the ISIA Institute in Urbino. Winner of the Urbino Rotary grant for the years 1978 to 1982.

(1983-1984)

Founding member of the Visual Design studio (Trento area), aimed at planning and promoting projects in a number of graphics, design and furnishing sectors.

(1984-1986)

Art director at an advertising agency in Brescia.

(1986)

He founded in Brescia the Leadergrafica studio, taking care of company and product image for firms, public institutions and private individuals.

(1993)

He moved to the country, going back to the original Visual name.

(1996 al 2000)

ACPI (Association of Italian Advertising Consultants) member. Founding member in the year 2000 of the Artex studio near Trento, a laboratory of ideas in the graphic design and realization of large prints on fabrics

He now lives and works in Villanuova Sul Clisi (BS) at his own Visual studio, a new 350 sqm building in minimalist style, designed with large free spaces.

Ronchi's work covers several sectors: industrial design, graphics, interior design, furnishing, home & object design, lighting, exhibitions, events.

# HOT LAB

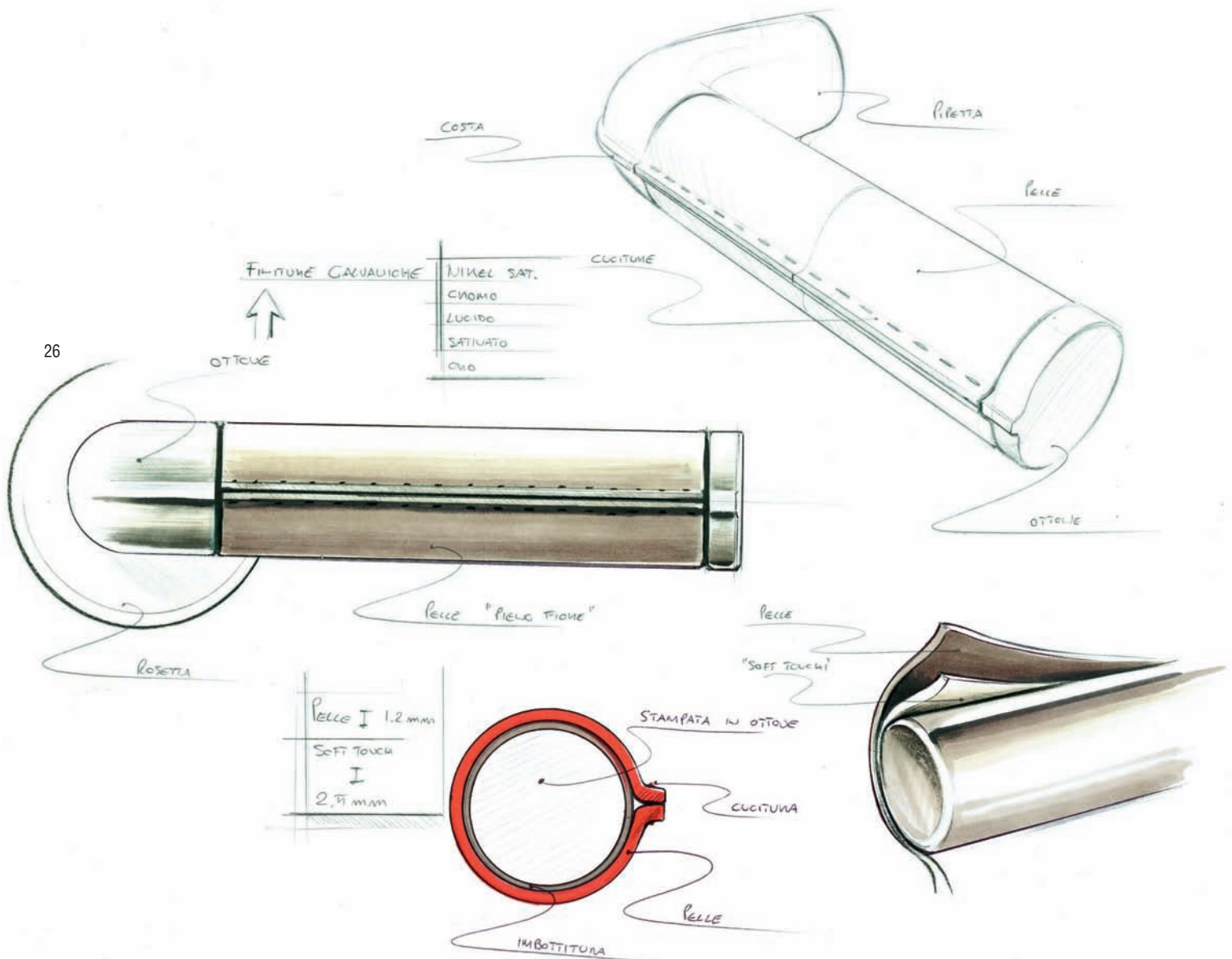



**STUDIO HOT LAB**  
Yacht & Design

Nasce nel 2004 a Milano, per iniziativa dei tre soci Michele Dragoni, Enrico Lumini e Antonio Romano, provenienti dal mondo dell'auto, dell'architettura e del design. Fin dagli inizi lo studio intraprende importanti progetti nel campo dello Yacht Design lavorando sia per armatori privati che per noti cantieri e broker, distinguendosi per l'accurata ricerca formale che caratterizza uno stile sobrio ed elegante. I soci trasferiscono sapientemente l'esperienza del design automobilistico nel dominio nautico e, allo stesso tempo, portano l'esperienza della progettazione nautica nel settore del Product Design.

In quest'ambito lo Studio disegna cucine, sedili di guida, penne, lampade, maniglie, occhiali, allestimenti per interni, stand espositivi, complementi d'arredo, macchine pulitrici industriali per grandi spazi per note aziende italiane ed estere. In pochi anni lo Studio Hot Lab progetta inoltre diversi yachts, lavorando in Italia, Francia, Grecia, Monaco, Regno Unito, Turchia, Egitto, Cina... ottiene importanti soddisfazioni e riconoscimenti per sé e per i propri clienti, premi e pubblicazioni su note riviste di yachting, design, architettura e lifestyle, collabora con prestigiose università italiane e partecipa a mostre e tavole rotonde.

*The Hot Lab Studio was founded in 2004 in Milan, from an original idea of the three young founding members Michele Dragoni, Enrico Lumini and Antonio Romano who came from the world of architecture, car and design. The Studio deals with Yacht, Product and Interior Design. After a relatively short time, it can already claim numerous awards and mentions on prestigious yachting, design and architecture magazines.*

*From cars to interior design and furnishing accessories, up to yacht construction planning. Hot Lab Studio's excellence and versatility are also expressed in a great attention to details. "God is in the details" used to say Mies van Der Rohe, the famous rationalist architect, and that's the way Dragoni, Lumini and Romano feel, founding their designer originality on a philosophy of details. Sober lines, essential elegance and extremely fine details are three key elements behind the basic idea of a studio that since its very opening followed an innovative approach in its work: an almost alchemic way to match thought and image, putting them together to produce new ideas.*

## CONDIZIONI GENERALI DI VENDITA

### **ORDINI**

Tutti gli ordini ricevuti direttamente o tramite nostri Agenti sono subordinati all'accettazione della Casa.

Gli ordini telefonici o verbali sono considerati validi dopo il ricevimento della conferma d'ordine.

Eventuali aggiunte agli ordini già in corso vengono accettate con riserva e possono ritardare il termine di consegna concordato.

La FMN Martinelli SPA non è ritenuta responsabile di errori nell'evasione degli ordini se questi sono causati da errata o incompleta indicazione nell'ordine.

La FMN Martinelli SPA si riserva il diritto di apportare modifiche ai prodotti, ritenute necessarie, senza preavviso alcuno. Le misure tecniche indicate nel presente catalogo sono indicative.

### **CONSEGNA**

La FMN Martinelli SPA si impegna a rispettare il più fedelmente possibile la data di consegna richiesta dal Committente. La data di consegna stabilita ha comunque solo carattere indicativo. Eventuali ritardi e la mancata o parziale consegna non comportano richieste di indennizzo. Gli ordini possono essere evasi anche parzialmente con riserva da parte della Casa di annullare la rimanenza.

### **PREZZI**

I prezzi esposti nel listino si intendono in Euro IVA esclusa, resa franco nostra fabbrica. Gli stessi possono essere aumentati anche prima dell'evasione dell'ordine se nel frattempo intervengono forti variazioni sul costo della materia prima.

### **IMBALLI**

**Gli imballi sono compresi nel prezzo. Le quantità sono indicate nel listino. Per ordini di quantità inferiore la FMN Martinelli SPA si riserva di aumentarla fino a raggiungere il quantitativo della confezione. Per richieste di quantitativi inferiori viene applicata una maggiorazione del 10% sul prezzo di listino.**

### **VALORE MINIMO D'ORDINE**

**Il valore minimo dell'ordine è di Euro 350,00. Per ordini di importo inferiore viene addebitato un extra di Euro 35.00.**

### **TRASPORTO**

La merce viaggia sempre ad esclusivo rischio del Committente, anche se resa franco destino. La FMN Martinelli SPA non è responsabile per ritardi, manomissioni, furti o altre mancanze avvenute durante il trasporto.

Il Committente ha l'obbligo di ritirare la merce e verificarne la conformità al momento della consegna. In caso di mancato ritiro vengono addebitate tutte le spese sostenute oltre ad una ritenuta del 20% sul valore della merce ritornata in perfetto stato.

Le spese di trasporto sono sempre a carico del Committente, salvo particolari accordi.

### **RECLAMI**

Eventuali reclami devono essere fatti pervenire presso la sede della FMN Martinelli SPA entro e non oltre otto giorni dal ricevimento della merce, pena la decadenza. Per prodotti difettosi o non corrispondenti all'ordine la FMN Martinelli SPA ritirerà il materiale a proprie spese effettuandone la sostituzione o accreditandone l'importo relativo. Nessun altro risarcimento è dovuto.

### **PAGAMENTI**

I pagamenti devono essere effettuati nei termini convenuti ed inoltrati esclusivamente al domicilio della FMN Martinelli SPA.

In caso di ritardato pagamento, la pretesa degli interessi, ai sensi del D.Lgs. 231/2002, sarà richiesta previa la messa in mora, ai tassi previsti dallo stesso decreto legislativo.

### **RISERVA DI PROPRIETA'**

La merce fornita rimane di proprietà della FMN Martinelli SPA fino al pagamento completo della stessa. Anche nel caso in cui la merce venga rivenduta, pignorata o acquisita da procedura fallimentare o concorsuale.

Il ricavato di una vendita anche forzata andrà alla FMN Martinelli SPA fino ad esaurimento del credito.

### **COMPETENZA**

Per qualsiasi controversia si intende competente il Foro di Brescia

#### **ORDERS**

All direct orders as well as those received through our Agents are subject to our approval.

Orders received by telephone or verbally are only considered valid after receipt of order confirmation. Any addition to orders on which production has started are accepted with reserve and may delay the agreed delivery terms.

FMN Martinelli SpA is not responsible for mistakes in the execution of the orders if these are caused by incorrect or incomplete information received in the original order.

FMN Martinelli SpA reserves the right to bring modifications to the products, which are considered necessary, without any prior information. The technical measurements indicated in this catalogue are indicative.

#### **DELIVERY**

FMN Martinelli SpA undertakes to respect, wherever possible, the delivery date requested by the Buyer. However, all despatch dates quoted by FMN Martinelli are to be considered approximate. Any delay, missing or partial shipment do not entitle the Buyer to any claim or indemnity.

All orders can also be partially shipped and we reserve the right to cancel any balances outstanding.

#### **PRICES**

All prices quoted are ex-VAT. Should any heavy increase in cost of raw material occur then we reserve the right to increase prices even before shipment of the order.

#### **PACKING**

All packing is included in the price. Box quantities are indicated in the price-list. FMN Martinelli reserve the right to increase any smaller quantities to box quantity.

If this is not acceptable to the Buyer then we may apply a surcharge of 10% to price quoted in the price list.

#### **MINIMUM ORDER VALUE**

The minimum order value we accept is Eur 350,00. For lower value orders we may apply a surcharge of Eur 35,00.

For export orders – please contact our export department for more information.

#### **TRANSPORT**

The goods always travel at the Buyer's risk even if goods are delivered carriage paid. FMN Martinelli SpA is not responsible for delays, tamperings, burglaries or other shortcomings during the carriage.

The Buyer is bound to collect the goods and check their conformity on arrival.

In case of non-collection of the goods, we will debit the Buyer with all costs incurred plus a 20% of the goods value as re-stocking charge when the goods are returned to us.

The transport costs are always at Buyer's expense unless special terms have been agreed.

#### **CLAIMS**

Claims for shortages, damaged goods or incorrect supply must be made within 8 days from receipt of order.

In the event of goods proving faulty we will replace them or credit them but in doing so, no further liability, consequential or otherwise, is accepted.

No further indemnity is due.

#### **PAYMENT**

All payments are to be made within the agreed terms and exclusively to the domicile of FMN Martinelli SpA.

In case of delayed payment interest will be charged, according to the Decree Law 231/2002, at the rates stated by the same Decree Law.

#### **RESERVE OF OWNERSHIP**

All goods remain property of FMN Martinelli SpA until they are paid for in full.

All goods remain of our ownership even if passed to a third party, distrained or acquired by bankruptcy.

All proceeds from a sale even forced will be passed to FMN Martinelli SpA until the complete clearance of the credit.

#### **JURISDICTION:**

For any dispute, the jurisdiction is the Law Court of Brescia, Italy.

### Brass material finishes

<b>OLV</b>	Polished brass lacquered
<b>OS</b>	Satin brass lacquered
<b>OLS</b>	Polished brass + satin brass lacquered
<b>OC</b>	Polished chrome
<b>OCS</b>	Satin chrome
<b>CCS</b>	Polished chrome + satin chrome
<b>CNS</b>	Polished chrome + satin nickel lacquered
<b>ONS</b>	Satin nickel lacquered
<b>NNS</b>	Polished nickel + satin nickel lacquered
<b>ORO</b>	Gold plated 24K
<b>PVD</b>	<b>Stainless Brass®</b> brass colour
<b>PVD INOX</b>	<b>Stainless Brass®</b> steel colour



### Brass & wood finishes

<b>LPA</b>	Polished brass + palisander wood
<b>CPA</b>	Polished chrome + palisander wood
<b>TPA</b>	Satin chrome + palisander wood
<b>NPA</b>	Satin nickel + palisander wood
<b>LNO</b>	Polished brass + american walnut wood
<b>CNO</b>	Polished chrome + american walnut wood
<b>TNO</b>	Satin chrome + american walnut wood
<b>NNO</b>	Satin nickel + american walnut wood

### BLIP range of finishes

material: aluminium

<b>AC</b>	Polished chrome
<b>ACS</b>	Satin chrome
<b>ANS</b>	Satin nickel
<b>K1</b>	LIME COLOR
<b>K2</b>	FUCHSIA COLOR
<b>K3</b>	LILAC COLOR
<b>AT</b>	ANTHRACITE COLOR
<b>PVD</b>	<b>Stainless Brass®</b>
<b>PVD INOX</b>	<b>Stainless Brass®</b> steel finish



### HAVANA range of finishes

material: brass + first quality leather

<b>OLV + PA</b>	Polished brass + Papaya
<b>OCS + PA</b>	Satin chrome + Papaya
<b>OC + NA</b>	Polished chrome + Navy
<b>OCS + NA</b>	Satin chrome + Navy
<b>OC + PO</b>	Polished chrome + Pomerol
<b>OCS + PO</b>	Satin chrome + Pomerol

<b>OC + K1</b>	Polished chrome + LIME COLOR
<b>OC + K2</b>	Polished chrome + FUCHSIA COLOR
<b>OC + K3</b>	Polished chrome + LILAC COLOR
<b>OC + AT</b>	Polished chrome + ANTHRACITE COLOR

## 30 FINISHES SPECIFICATIONS AND TESTS

Finishes	Product	Process	Covering thickness in micron	Test procedures	RESULTS
<b>OLV - OS - OLS</b> <b>ONS</b> (test made on the lacquer)	Transparent bright alkyd melamine lacquer	Electrostatic automatic. Stoving at 170°	20 ÷ 25	100 wipes with acetone Dipping in acetone for 24 hours Dipping in ethyl alcohol at 95° for 24 hours Dipping in aqueous solution of sodium hypochlorite at 5% for 24 hours Dipping in aqueous solution of acetic acid at 10% for 24 hours <b>Corrosion test in salt spray according to the ISO 9227 ASTM B117 DIN 50021 standards up to 420 hours*</b> Adhesion test - by a ribbon pull on 2 square centimeters (2x2)	no change light and temporary softening light and temporary softening no change no change no change no change no lacquer detachment
<b>OC - OCS - CCS</b>	Chrome: Bayer chromic acid Nickel: inco rounds electrolytic nickel	Galvanic	Chrome 0,10 ÷ 0,15 Nickel: 2,00 ÷ 2,10	<b>Corrosion test in salt spray according to the ISO 9227 ASTM B117 DIN 50021 standards up to 700 hours*</b>	no change
<b>ONS - NNS - CNS</b>	Nickel + lacquering	Galvanic + Electrostatic automatic. Stoving at 170°	Nickel: 2,00 ÷ 2,10 Lacquer: 20 ÷ 25	See the lacquer tests	no change
<b>ORO</b>	Nickel: inco rounds electrolytic nickel + 24K Gold plating	Galvanic	Nickel: 2,00 ÷ 2,10 Gold: 0,05	See the lacquer tests	no change
<b>PVD</b> <b>Stainless Brass®</b>	Zirconium or Titanium combined with reactive gas	Metallic coating known as Physical Vapor Deposition		<b>Corrosion test in salt spray according to the ISO 9227 ASTM B117 DIN 50021 standards up to 1500 hours*</b>	no change
<b>PVD INOX</b> <b>Stainless Brass®</b>	Zirconium or Titanium combined with reactive gas	Metallic coating known as Physical Vapor Deposition		<b>Corrosion test in salt spray according to the ISO 9227 ASTM B117 DIN 50021 standards up to 1500 hours*</b>	no change
				<b>Mechanical components wear and tear test</b> Opening /closing simulation (DM 236/89) - over 800.000 cycles	no change

\* 80 hours in salt spray correspond to 1 years use (in normal use conditions)

The corrosion test in salt spray is the most critical test of those we have indicated above

**Finiture su ottone**

<b>OLV</b>	Ottone lucido verniciato
<b>OS</b>	Ottone satinato verniciato
<b>OLS</b>	Ottone lucido + ottone satinato verniciato
<b>OC</b>	Ottone cromo lucido
<b>OCS</b>	Ottone cromo satinato
<b>CCS</b>	Ottone cromo lucido + cromo satinato
<b>CNS</b>	Ottone cromo lucido + nickel satinato verniciato
<b>ONS</b>	Ottone nickel satinato verniciato
<b>NNS</b>	Ottone nickel lucido + nickel satinato verniciato
<b>ORO</b>	Ottone placcato oro 24K
<b>PVD</b>	PVD colore ottone <b>Stainless Brass®</b>
<b>PVD INOX</b>	PVD colore acciaio <b>Stainless Brass®</b>

**Finiture su ottone con legno**

<b>LPA</b>	Ottone lucido + palissandro
<b>CPA</b>	Ottone cromo lucido + palissandro
<b>TPA</b>	Ottone cromo satinato + palissandro
<b>NPA</b>	Ottone nickel satinato + palissandro
<b>LNO</b>	Ottone lucido + noce americana
<b>CNO</b>	Ottone cromo lucido + noce americana
<b>TNO</b>	Ottone cromo satinato + noce americana
<b>NNO</b>	Ottone nickel satinato + noce americana

**Finiture serie BLIP  
materiale: alluminio**

<b>AC</b>	Cromo lucido
<b>ACS</b>	Cromo satinato
<b>ANS</b>	Nickel satinato
<b>K1</b>	Colore "LIME"
<b>K2</b>	Colore "FUCSIA"
<b>K3</b>	Colore "LILLA"
<b>AT</b>	Colore "ANTRACITE"
<b>PVD</b>	PVD colore ottone <b>Stainless Brass®</b>
<b>PVD INOX</b>	PVD colore acciaio <b>Stainless Brass®</b>



<b>OC + K1</b>	Ottone cromo lucido + Colore "LIME"
<b>OC + K2</b>	Ottone cromo lucido + Colore "FUCSIA"
<b>OC + K3</b>	Ottone cromo lucido + Colore "LILLA"
<b>OC + AT</b>	Ottone cromo lucido + Colore "ANTRACITE"

**Finiture serie HAVANA**
**materiale: ottone + pelle di prima qualità "PIENO FIORE"**

<b>OLV + PA</b>	Ottone lucido + Papaya
<b>OCS + PA</b>	Ottone cromo satinato + Papaya
<b>OC + NA</b>	Ottone cromo lucido + Navy
<b>OCS + NA</b>	Ottone cromo satinato + Navy
<b>OC + PO</b>	Ottone cromo lucido + Pomerol
<b>OCS + PO</b>	Ottone cromo satinato + Pomerol

**CARATTERISTICHE E TEST DELLE FINITURE**

FINITURE	PRODOTTO	PROCESSO	SPESSORE MICRON	TEST	RISULTATO
<b>OLV - OS - OLS</b> <b>ONS</b> (su vernice)	Vernice trasparente lucida alchidica melaminica	Elettrostatico automatico. Cottura a 170°	20 ÷ 25	100 passaggi con acetone Immersione in acetone per 24 ore Immersione in alcool etilico a 95° per 24 ore Immersione in soluzione acquosa di ipoclorito di sodio al 5% per 24 ore Immersione in soluzione acquosa di acido acetico al 10% per 24 ore <b>Prova di resistenza alla corrosione in nebbia salina come da norme ISO 9227 ASTM B117 DIN 50021 fino a 420 ore*</b> Prova di aggrappaggio mediante strappo su quadrettatura di 2 cm <sup>2</sup>	nessuna alterazione leggero e temporaneo rammollimento leggero e temporaneo rammollimento nessuna alterazione nessuna alterazione nessuna alterazione nessuna alterazione nessun distacco
<b>OC - OCS - CCS</b>	Cromo: acido cromico Bayer Nickel: inco rounds nickel elettrolitico	Galvanico	Cromo 0,10 ÷ 0,15 Nickel: 2,00 ÷ 2,10	<b>Prova di resistenza alla corrosione in nebbia salina come da norme ISO 9227 ASTM B117 DIN 50021 fino a 700 ore*</b>	nessuna alterazione
<b>ONS - NNS - CNS</b>	Nickel + vernice	Galvanico + elettrostatico automatico. Cottura a 170°	Nickel: 2,00 ÷ 2,10 Vernice: 20 ÷ 25	Vedi test su vernice	nessuna alterazione
<b>ORO</b>	Nickel: inco rounds nickel elettrolitico + Film di ORO 24K	Galvanico	Nickel: 2,00 ÷ 2,10 Oro: 0,05	Vedi test su vernice	nessuna alterazione
<b>PVD</b> <b>Stainless Brass®</b>	Zirconio o Titanio abbinati a gas reattivi	Sottovuoto		<b>Prova di resistenza alla corrosione in nebbia salina come da norme ISO 9227 ASTM B117 DIN 50021 fino a 1500 ore*</b>	nessuna alterazione
<b>PVD INOX</b> <b>Stainless Brass®</b>	Zirconio o Titanio abbinati a gas reattivi	Sottovuoto		<b>Prova di resistenza alla corrosione in nebbia salina come da norme ISO 9227 ASTM B117 DIN 50021 fino a 1500 ore*</b>	nessuna alterazione
				<b>TEST DI USURA MOVIMENTO MECCANICO</b> Prova di simulazione apertura/chiusura (DM 236/89) oltre a 800.000 movimenti	nessuna usura

\* 80 ore in nebbia salina = un anno di durata (in normali condizioni di utilizzo)  
La prova di resistenza alla corrosione in nebbia salina è il test più determinante fra quelli sopra riportati

## FINITURE - FINISHES

32

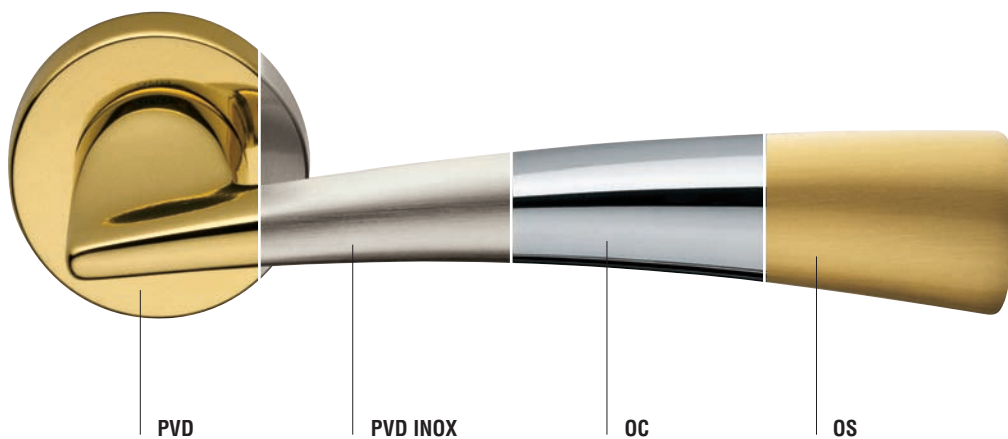

### **PVD - PVD INOX: Stainless Brass®**

Rivestimento metallico sottovuoto denominato PVD (Physical Vapor Deposition).

Inossidabile, anti-graffio e anti-usura.

Mantiene inalterato nel tempo il colore di origine.

Il rivestimento testato in nebbia salina in base alle norme ISO 9227

ASTMB117 DIN 50021 ha superato le 1500 ore di resistenza.

Garantito 20 anni (in normali condizioni di utilizzo)

Per la pulizia di questo rivestimento consigliamo di utilizzare un panno morbido inumidito con alcool.

### **PVD - PVD INOX: Stainless Brass®**

*Metallic coating named PVD (Physical Vapor Deposition).*

*Inoxidizable, scratch-resistant and wearproof, PVD maintains the original colour unchanged over the time.*

*PVD coating exceeded 1500 hours in the salt fog resistance test in accordance with the ISO 9227 ASTMB117 DIN 50021 specifications*

*PVD is guaranteed for 20 years (for normal use conditions)*

*When cleaning this coating we suggest to use a soft cloth moisted*

*with alcohol only.*

### **OC**

ottone brillante con applicazione di cromo  
*bright brass with chrome plating*

### **OS**

colore naturale dell'ottone satinato  
*the natural colour of brass by silking operation*

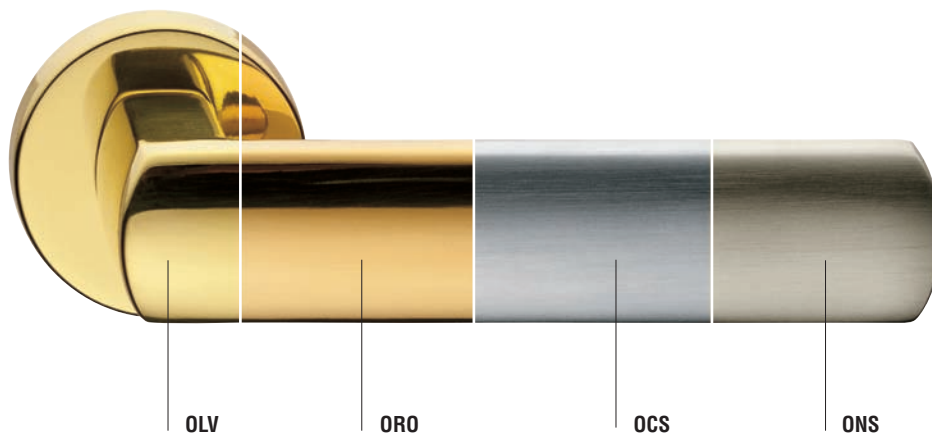

**OLV**

il colore naturale dell'ottone reso brillante mediante spazzolatura  
*the natural colour of brass made bright by the polishing operation*

**ORO**

ottone placcato oro 24K  
*bright brass with 24K Gold plating*

**OCS**

ottone satinato con applicazione di cromo  
*satin brass with chrome plating*

**ONS**

ottone satinato con applicazione di nickel  
*satin brass with nickel plating*

**Consigli per l'uso e la manutenzione:**

Procedere al montaggio solo dopo l'eventuale tinteggiatura di pareti ed infissi e dopo l'eventuale trattamento dei pavimenti.

Per la pulizia dei prodotti usare solo un panno morbido ed asciutto.

Il contatto con altre parti metalliche (chiavi, anelli, etc.) può danneggiare la superficie.

*Suggestions for use and maintenance:*

*Only proceed to mount the product after the eventual painting/lacquering of walls, windows or doors and after the eventual treatment for floors.*

*When cleaning the products use a soft dry cloth only.*

*Surface could be damaged by the contact with metallic objects (keys, rings, etc.)*

## FINITURE SERIE BLIP - BLIP SERIES FINISHES

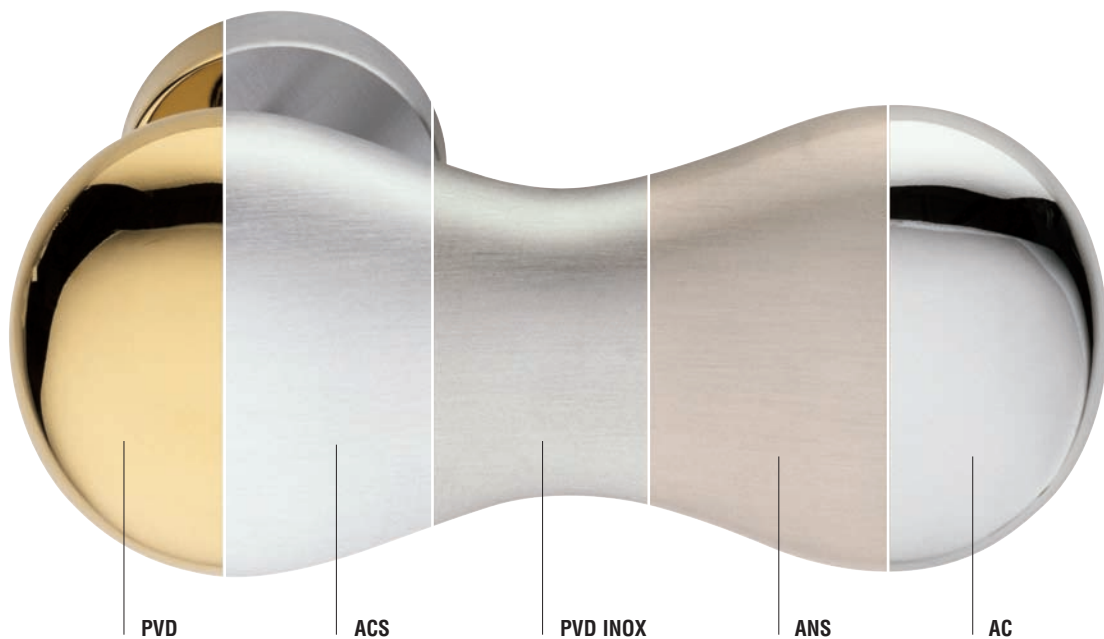

34

**Materiale: alluminio**  
**Material: aluminium**



**PVD - PVD INOX: Stainless Brass®**

Rivestimento metallico sottovuoto denominato PVD (Physical Vapor Deposition).  
Inossidabile, anti-graffio e anti-usura.  
Mantiene inalterato nel tempo il colore di origine.  
Il rivestimento testato in nebbia salina in base alle norme ISO 9227 ASTMB117 DIN 50021 ha superato le 1500 ore di resistenza.  
Garantito 20 anni (in normali condizioni di utilizzo)  
Per la pulizia di questo rivestimento consigliamo di utilizzare un panno morbido inumidito con alcool.

**PVD - PVD INOX: Stainless Brass®**

*Metallic coating named PVD (Physical Vapor Deposition).  
Inoxidizable, scratch-resistant and wearproof, PVD maintains the original colour unchanged over the time.  
PVD coating exceeded 1500 hours in the salt fog resistance test in accordance with the ISO 9227 ASTMB117 DIN 50021 specifications  
PVD is guaranteed for 20 years (for normal use conditions)  
When cleaning this coating we suggest to use a soft cloth moisted with alcohol only.*

**ACS**

Alluminio satinato con applicazione di cromo  
*Satin aluminium with chrome plating*

**ANS**

Alluminio satinato con applicazione di nickel e vernice trasparente  
*Satin aluminium with nickel plating and transparent lacquer*

**AC**

Alluminio spazzolato con applicazione di cromo  
*Polished aluminium with chrome plating*

FINITURE SERIE BLIP-FLUKE-SIKE  
BLIP-FLUKE-SIKE SERIES FINISHES

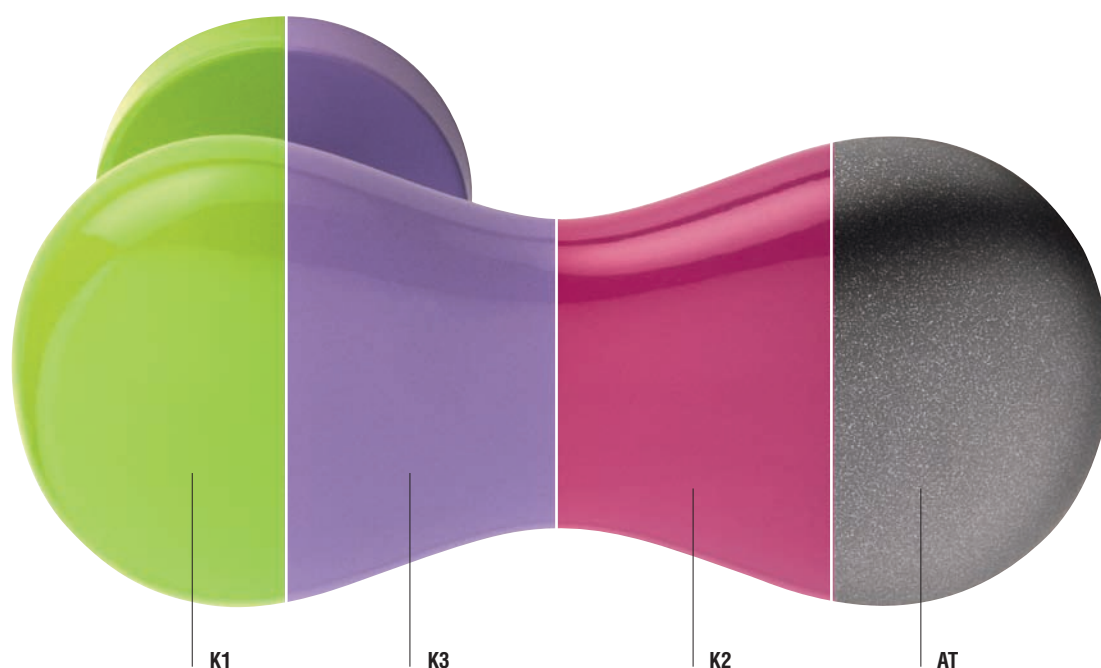

35

**K1**

Colore "LIME"  
LIME COLOR

**K2**

Colore "FUCSIA"  
FUCHSIA COLOR

**K3**

Colore "LILLA"  
LILAC COLOR

**AT**

Colore "ANTRACITE"  
ANTHRACITE COLOR

Consigli per l'uso e la manutenzione:

Procedere al montaggio solo dopo l'eventuale tinteggiatura di pareti ed infissi e dopo l'eventuale trattamento dei pavimenti.

Per la pulizia dei prodotti usare solo un panno morbido ed asciutto.

Il contatto con altre parti metalliche (chiavi, anelli, etc.) può danneggiare la superficie.

*Suggestions for use and maintenance:*

*Only proceed to mount the product after the eventual painting/lacquering of walls, windows or doors and after the eventual treatment for floors.*

*When cleaning the products use a soft dry cloth only.*

*Surface could be damaged by the contact with metallic objects (keys, rings, etc.)*



Doppia applicazione di vernice colorata ad alta tenuta  
Double application of coloured paint - high resistance -



INDICE CATALOGO - CATALOGUE INDEX

Maniglie - <i>Door handles</i>	ART	112	Maniglioni	ART	124
	BLIP	68	<i>Pull handles</i>	ART	126
	BLIP COLORS	70		GO	128
	DOLCE	74		LINEAR	120
	DOLCE 02	76		LINEAR	122
	EDRA	42		LOGO	116
	EDRA 02	44		LOGO-B	118
	EGO	50			
	FLUKE	56	Pomoli - <i>Knobs</i>	ART	132
	FLUKE 02	58		FLUO'	136
	FLUKE COLOR	60		GO	134
	FLUO'	108			
	GO	110	Portabiti	ALGA	148
	HALLEY	106	<i>Coat hangers</i>	ALGA	150
	HAVANA	72		LOTO	142
	LINEAR	102		MEDUSA	144
	LINEAR 02	104		MEDUSA	146
	LOGO	96		MOBY	140
	LOGO-B	98			
	LOGO 02	100	Articoli vari	BOCCHETTE	158
	LUXURY	38	<i>Miscellaneous</i>	<i>Escutcheons</i>	
	LUXURY 02	40		NOTTOLINI	154
	MOVIDA	46		<i>Turns &amp; releases</i>	
	MOVIDA-B	48		PLACCHE	159
	SIKE	62		<i>Plates</i>	
	SIKE 02	64		ROSETTE	156
	SIKE COLOR	66		<i>Roses</i>	
	TWIST	52			
	TWIST 02	54		ESPOSITORI	162
	VITA	78		<i>Displays</i>	
	VITA-B	80		CONFEZIONI	160
	VITA-C	82		<i>Packaging</i>	
	VITA-D	84			
	VITA LEGNO	86	Sistemi di montaggio	MANIGLIE	168
	VITA 02	88	<i>Assembling systems</i>	<i>Door handles</i>	
	VITA S	90		MANIGLIONI	173
	ZEN	92		<i>Pull handles</i>	
	ZEN LEGNO	94		POMOLI	172
				<i>Door knobs</i>	
				PORTABITI	174
				<i>Coat hangers</i>	

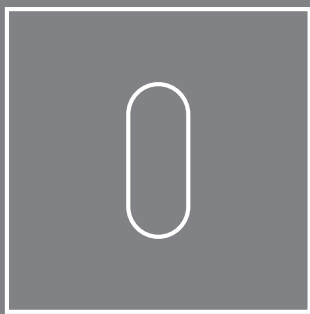
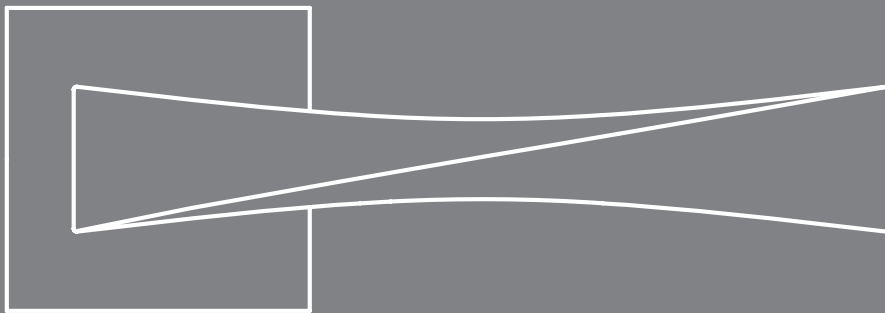



LU 15 - OC

FINITURE / FINISHES



OLV



OS



OC



OCS



ONS



PVD

FINITURE / FINISHES

OLV - OS - OC - OCS - ONS - ORO - PVD - PVD INOX

38

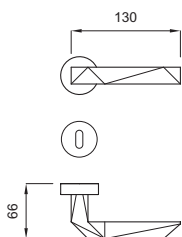

**LU 15**  
maniglia su rosetta e bocchetta 45 mm  
*door handle on rose and escutcheon 45 mm*

**LU 16**  
maniglia su rosetta e bocchetta 52 mm  
*door handle on rose and escutcheon 52 mm*

# LUXURY

Design: Mauro Ronchi

dnd  
diffusione nuova design

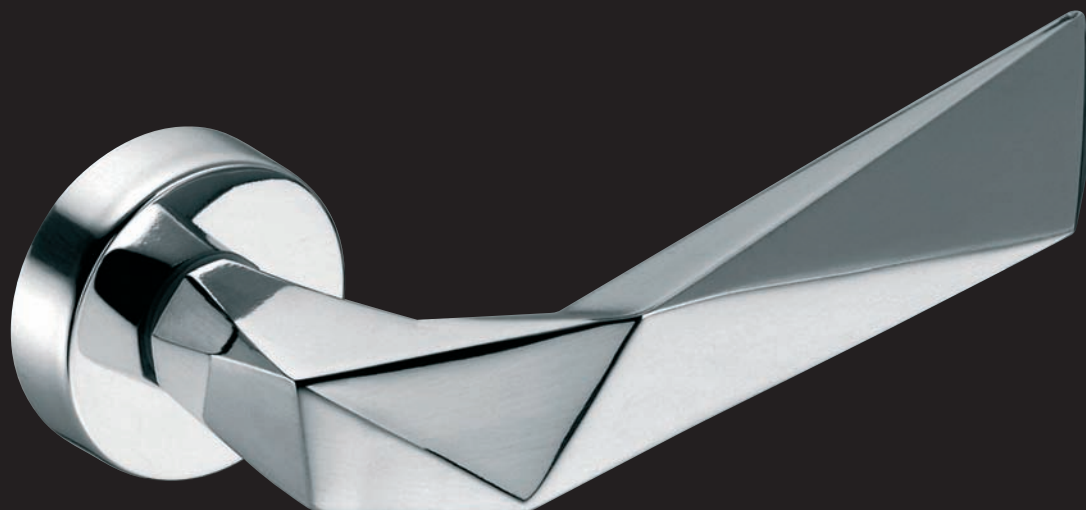

DI MANO IN MANO

# LUXURY 02

Design: Mauro Ronchi

ottone stampato a caldo - hot stamped brass



**LU 18 - OC**

## FINITURE / FINISHES



**OLV**



**OS**



**OC**

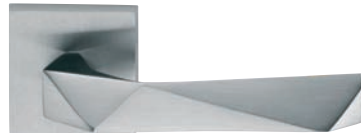

**OCS**



**ONS**



**PVD**

## FINITURE / FINISHES

OLV - OS - OC - OCS - ONS - ORO - PVD - PVD INOX

40

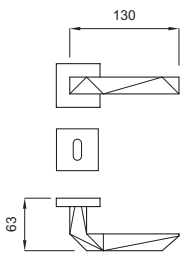

**LU 18**  
maniglia su rosetta e bocchetta quadra  
52 mm  
door handle on square rose and  
escutcheon 52 mm

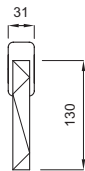

**LU 24**  
martellina DK quadro  
square DK window handle

# LUXURY 02

Design: Mauro Ronchi

dnd  
diffusione nuova design

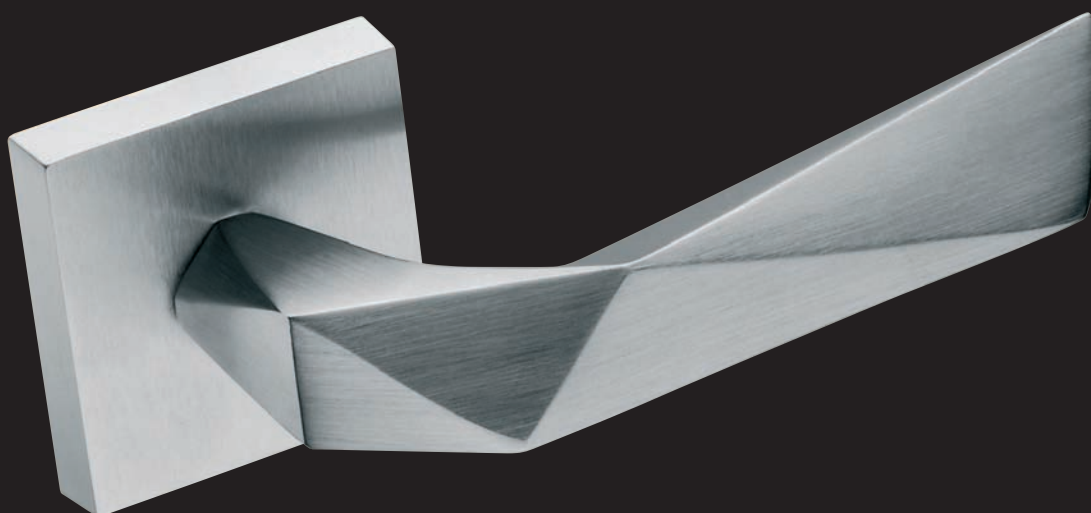

DI MANO IN MANO



ED 15 - OC

FINITURE / FINISHES



OLV



OS



OC



OCS



ONS



PVD

FINITURE / FINISHES  
OLV - OS - OC - OCS - ONS - PVD - PVD INOX

42

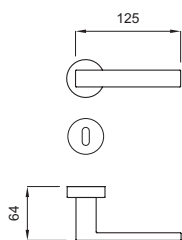

**ED 15**  
maniglia su rosetta e bocchetta 45 mm  
*door handle on rose and escutcheon 45 mm*

**ED 16**  
maniglia su rosetta e bocchetta 52 mm  
*door handle on rose and escutcheon 52 mm*

# EDRA

Design: Mauro Ronchi

dnd  
diffusione nuova design



DI MANO IN MANO

# EDRA 02

Design: Mauro Ronchi

ottone stampato a caldo - hot stamped brass



**ED 18 - OC**

## FINITURE / FINISHES



**OLV**



**OS**



**OC**



**OCS**



**ONS**



**PVD**

FINITURE / FINISHES  
OLV - OS - OC - OCS - ONS - PVD - PVD INOX

44

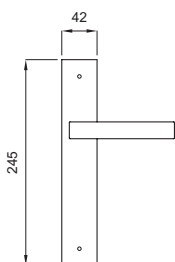

**ED 10**  
maniglia su placca Quadra  
door handle on Quadra plate

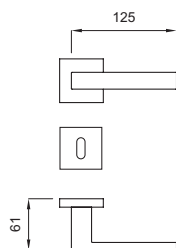

**ED 18**  
maniglia su rosetta e bocchetta  
quadra 52 mm  
door handle on square rose  
and escutcheon 52 mm

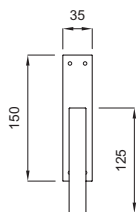

**ED 20**  
cremonese con meccanismo  
window handle with mechanism

**ED 21**  
martellina q.7 senza meccanismo  
window handle 7 mm square  
without mechanism

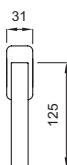

**ED 24**  
martellina DK quadro  
square DK window handle

# EDRA 02

Design: Mauro Ronchi

dnd  
diffusione nuova design

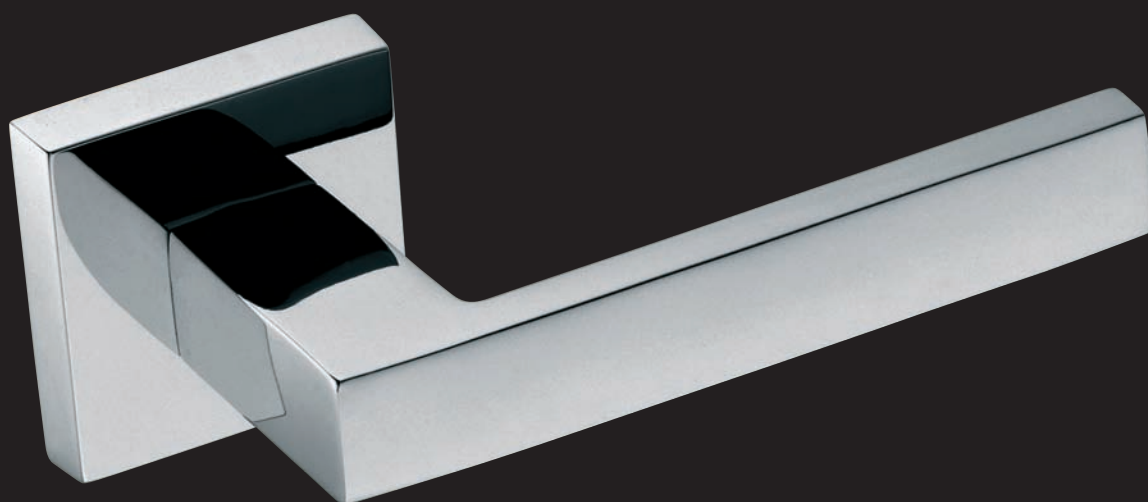

DI MANO IN MANO



**MV 16 - OC**

FINITURE / FINISHES



**OLV**



**OS**



**OC**



**OCS**



**ONS**



**PVD**

FINITURE / FINISHES  
OLV - OS - OC - OCS - ONS - PVD - PVD INOX

46

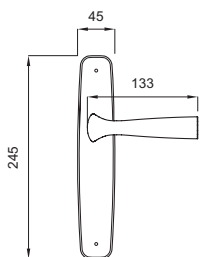

**MV 10**  
maniglia su placca  
door handle on plate

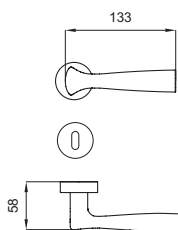

**MV 15**  
maniglia su rosetta e bocchetta 45 mm  
door handle on rose and escutcheon  
45 mm

**MV 16**  
maniglia su rosetta e bocchetta 52 mm  
door handle on rose and escutcheon  
52 mm

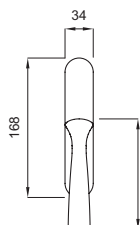

**MV 20**  
cremonese con meccanismo  
window handle with mechanism

**MV 21**  
martellina con meccanismo e q. 7x45 mm  
window handle with mechanism  
and 7x45 mm spindle

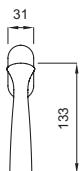

**MV 22**  
martellina DK  
DK window handle

# MOVIDA

Design: Mauro Ronchi

dnd  
diffusione nuova design



DI MANO IN MANO

# MOVIDA-B

Design: Mauro Ronchi

ottone stampato a caldo - hot stamped brass

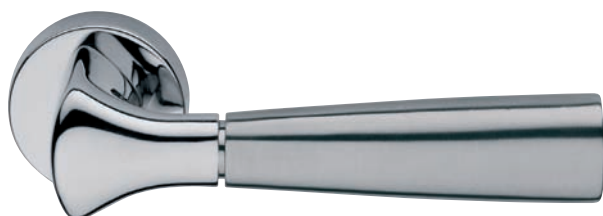

**MB 15 - CCS**

## FINITURE / FINISHES



**OLS**



**CCS**



**NNS**

48

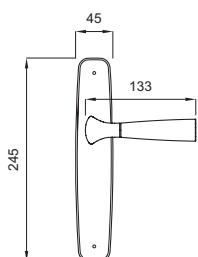

**MB 10**  
maniglia su placca  
*door handle on plate*

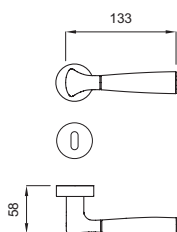

**MB 15**  
maniglia su rosetta e bocchetta 45 mm  
*door handle on rose and escutcheon 45 mm*

**MB 16**  
maniglia su rosetta e bocchetta 52 mm  
*door handle on rose and escutcheon 52 mm*

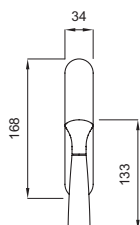

**MB 20**  
cremonese con meccanismo  
*window handle with mechanism*

**MB 21**  
martellina con meccanismo e q. 7x45 mm  
*window handle with mechanism and 7x45 mm spindle*

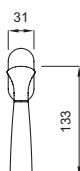

**MB 22**  
martellina DK  
*DK window handle*

FINITURE / FINISHES  
OLS - CCS - NNS

# MOVIDA-B

Design: Mauro Ronchi

dnd  
diffusione nuova design



DI MANO IN MANO



**EG 15 - OC**

FINITURE / FINISHES



**OLV**



**OS**



**OC**



**OCS**



**ONS**



**PVD**

FINITURE / FINISHES  
OLV - OS - OC - OCS - ONS - PVD - PVD INOX

50

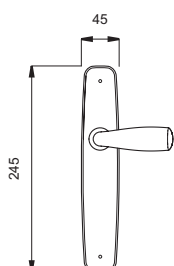

**EG 10**  
maniglia su placca  
door handle on plate

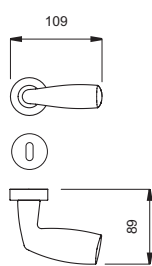

**EG 15**  
maniglia su rosetta e bocchetta 45 mm  
door handle on rose and escutcheon  
45 mm

**EG 16**  
maniglia su rosetta e bocchetta 52 mm  
door handle on rose and escutcheon  
52 mm

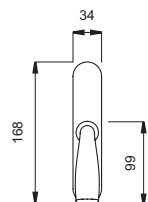

**EG 20**  
cremonese con meccanismo  
window handle with mechanism

**EG 21**  
martellina con meccanismo e q. 7x45 mm  
window handle with mechanism  
and 7x45 mm spindle



**EG 22**  
martellina DK  
DK window handle

# EGO

Design: Mauro Ronchi



DI MANO IN MANO

# TWIST

Design: Karim Rashid

ottone stampato a caldo - hot stamped brass



**TW 14 - OC**

## FINITURE / FINISHES



**OLV**



**OS**



**OCS**



**OC**



**ONS**



**PVD**

## FINITURE / FINISHES

OLV - OS - OLS - OC - OCS - CCS - ONS - PVD - PVD INOX

52

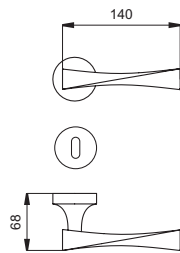

**TW 14**  
maniglia su rosetta e bocchetta  
52 mm  
door handle on rose and escutcheon  
52 mm

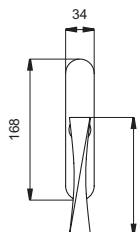

**TW 20**  
cremonese con meccanismo  
window handle with mechanism

**TW 21**  
martellina con meccanismo e q. 7x45 mm  
window handle with mechanism  
and 7x45 mm spindle

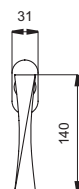

**TW 22**  
martellina DK  
DK window handle

# TWIST

Design: Karim Rashid

dnd  
diffusione nuova design

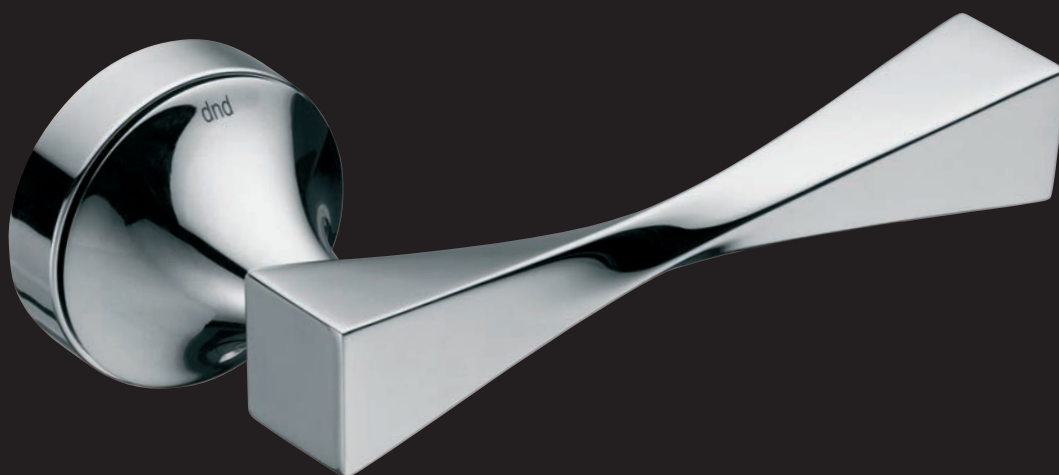

DI MANO IN MANO

# TWIST 02

Design: Karim Rashid

ottone stampato a caldo - hot stamped brass



**TW 18 - CCS**

## FINITURE / FINISHES



**OLS**



**OS**



**CCS**



**OCS**



**ONS**

## FINITURE / FINISHES

OLV - OS - OLS - OC - OCS - CCS - ONS - PVD - PVD INOX

54

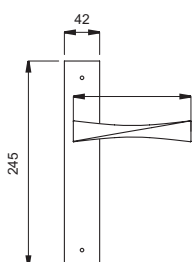

**TW 10**  
maniglia su placca Quadra  
door handle on Quadra plate

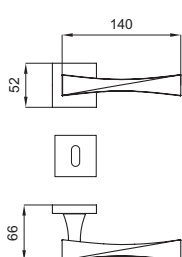

**TW 18**  
maniglia su rosetta e bocchetta quadra  
52 mm  
door handle on square rose  
and escutcheon 52 mm

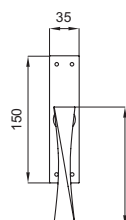

**TW 23**  
cremonese con meccanismo  
window handle with mechanism

**TW 24**  
martellina q.7 mm senza meccanismo  
window handle 7 mm square  
without mechanism

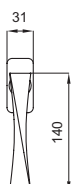

**TW 25**  
martellina DK quadro  
square DK window handle

# TWIST 02

Design: Karim Rashid



DI MANO IN MANO



FK 14 - OLV

FINITURE / FINISHES



OLV



OS



OC



OCS



PVD



PVD INOX

FINITURE / FINISHES

OLV - OS - OC - OCS - ONS - PVD - PVD INOX

56

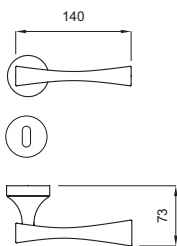

**FK 14**  
maniglia su rosetta e bocchetta  
52 mm  
door handle on rose and escutcheon  
52 mm

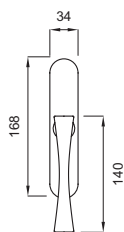

**FK 20**  
cremonese con meccanismo  
window handle with mechanism

**FK 21**  
martellina con meccanismo e q. 7x45 mm  
window handle with mechanism  
and 7x45 mm spindle

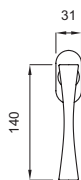

**FK 22**  
martellina DK  
DK window handle

# FLUKE

Design: Karim Rashid

dnd  
diffusione nuova design



DI MANO IN MANO

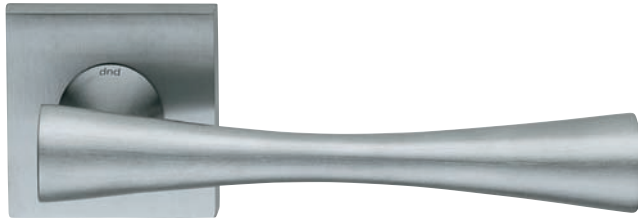

**FK 18 - OCS**

FINITURE / FINISHES



**OLV**



**OS**



**OC**



**ONS**



**PVD**



**PVD INOX**

FINITURE / FINISHES

OLV - OS - OC - OCS - ONS - PVD - PVD INOX



OC+K1 - OC+K2 - OC+K3 - OC+AT

58

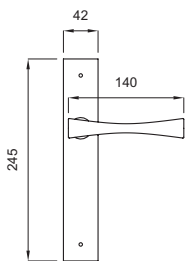

**FK 10**  
maniglia su placca Quadra  
door handle on Quadra plate

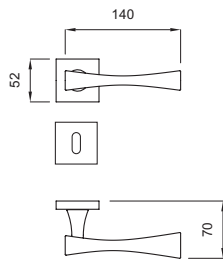

**FK 18**  
maniglia su rosetta e bocchetta quadra  
52 mm  
door handle on square rose  
and escutcheon 52 mm

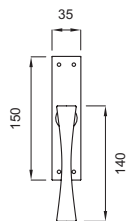

**FK 23**  
cremonese con meccanismo  
window handle with mechanism

**FK 24**  
martellina q.7 mm senza meccanismo  
window handle 7 mm square  
without mechanism

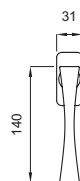

**FK 25**  
martellina DK quadro  
square DK window handle

# FLUKE 02

Design: Karim Rashid

dnd  
diffusione nuova design

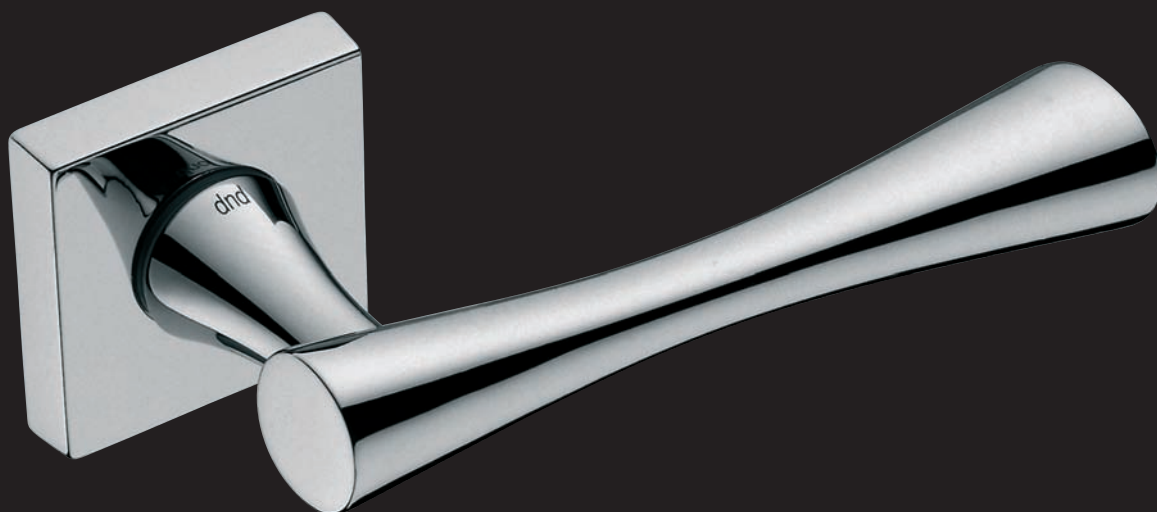

DI MANO IN MANO

# FLUKE COLOR

Design: Karim Rashid

ottone stampato a caldo - hot stamped brass



**FK 14 - OC+AT**

## FINITURE / FINISHES



**OC + K1**



**OC + K2**



**OC + K3**



**OC + AT**

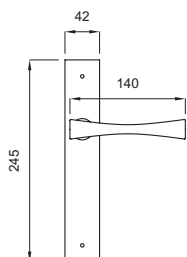

**FK 10**  
maniglia su placca Quadra  
*door handle on Quadra plate*

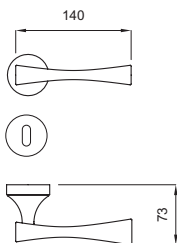

**FK 14**  
maniglia su rosetta e bocchetta  
52 mm  
*door handle on rose and escutcheon  
52 mm*

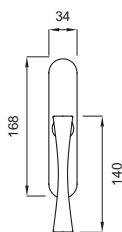

**FK 20**  
cremonese con meccanismo  
*window handle with mechanism*

**FK 21**  
martellina con meccanismo e q. 7x45 mm  
*window handle with mechanism  
and 7x45 mm spindle*

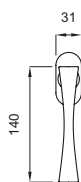

**FK 22**  
martellina DK  
*DK window handle*



FINITURE / FINISHES  
OC+K1 - OC+K2 - OC+K3 - OC+AT

# FLUKE COLOR

Design: Karim Rashid



DI MANO IN MANO

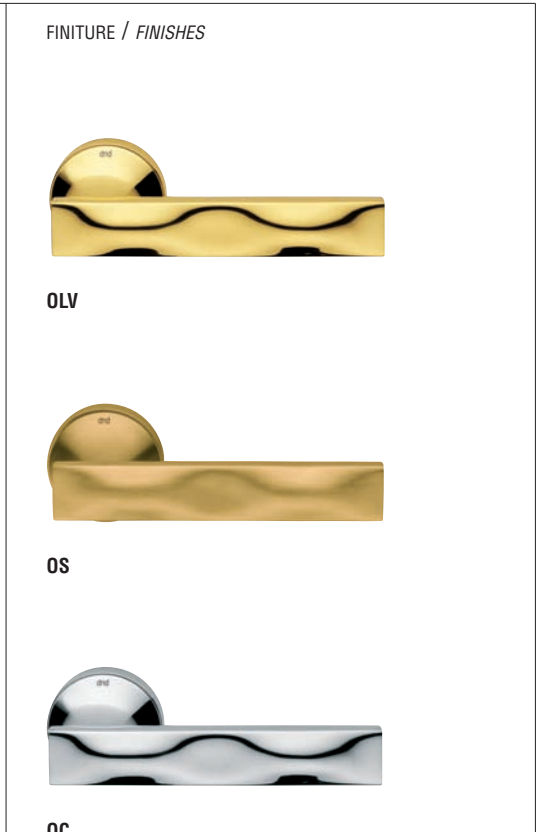
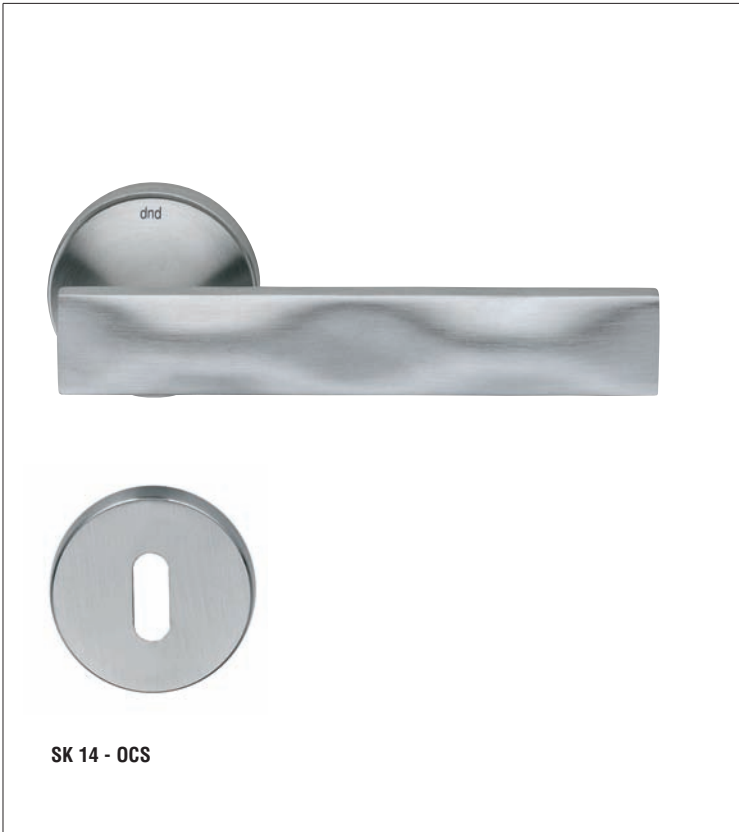

62

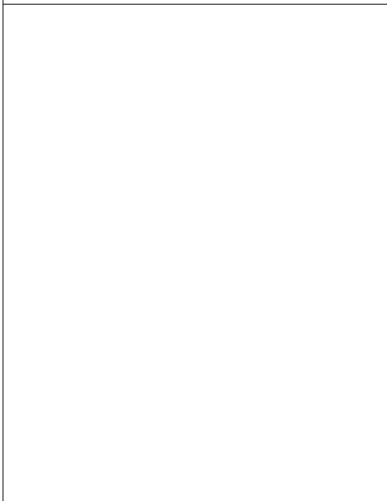

140

72

**SK 14**  
maniglia su rosetta e bocchetta  
52 mm  
door handle on rose and escutcheon  
52 mm

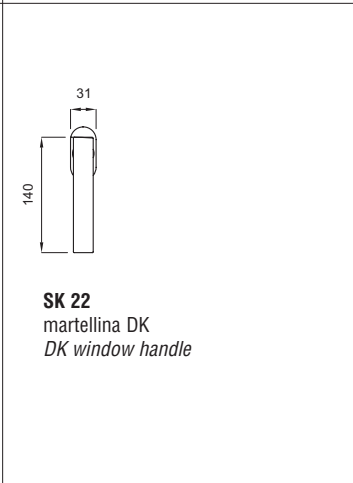
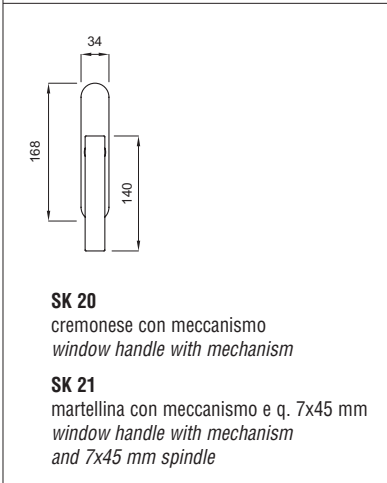
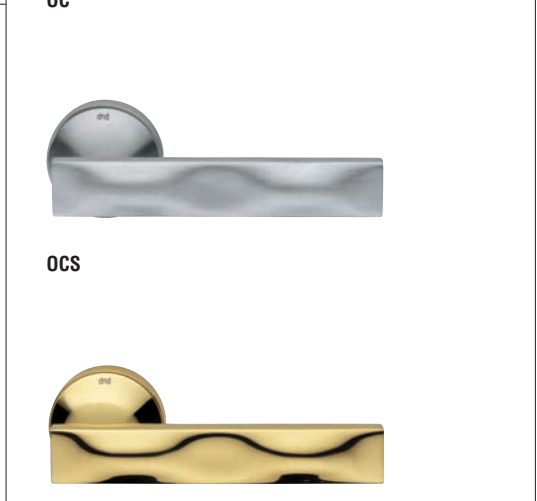

# SIKE

Design: Karim Rashid



DI MANO IN MANO



As awarded by The Chicago Athenaeum: Museum of Architecture and Design

# SIKE 02

Design: Karim Rashid

ottone stampato a caldo - hot stamped brass



SK 18 - OC

## FINITURE / FINISHES



OLV



OS



OC



OCS



ONS



PVD

## FINITURE / FINISHES

OLV - OS - OC - OCS - ONS - PVD - PVD INOX



OC+K1 - OC+K2 - OC+K3 - OC+AT

64

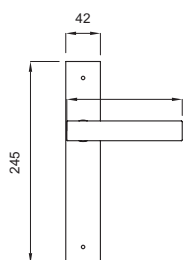

**SK 10**  
maniglia su placca Quadra  
door handle on Quadra plate

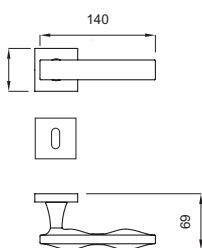

**SK 18**  
maniglia su rosetta e bocchetta quadra  
52 mm  
door handle on square rose  
and escutcheon 52 mm

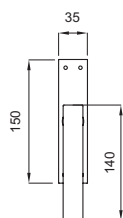

**SK 23**  
cremonese con meccanismo  
window handle with mechanism

**SK 24**  
martellina q.7 mm senza meccanismo  
window handle 7 mm square  
without mechanism

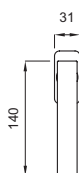

**SK 25**  
martellina DK quadro  
square DK window handle

# SIKE 02

Design: Karim Rashid



DI MANO IN MANO

# SIKE COLOR

Design: Karim Rashid

ottone stampato a caldo - hot stamped brass



SK 14 - OC+K2

## FINITURE / FINISHES



OC + K1



OC + K2



OC + K3



OC + AT

66

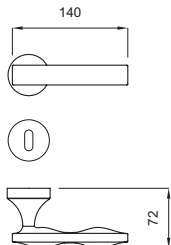

**SK 14**  
maniglia su rosetta e bocchetta  
52 mm  
door handle on rose and escutcheon  
52 mm

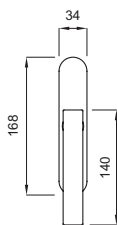

**SK 20**  
cremonese con meccanismo  
window handle with mechanism

**SK 21**  
martellina con meccanismo e q. 7x45 mm  
window handle with mechanism  
and 7x45 mm spindle

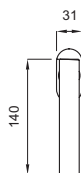

**SK 22**  
martellina DK  
DK window handle



FINITURE / FINISHES  
OC+K1 - OC+K2 - OC+K3 - OC+AT

# SIKE COLOR

Design: Karim Rashid

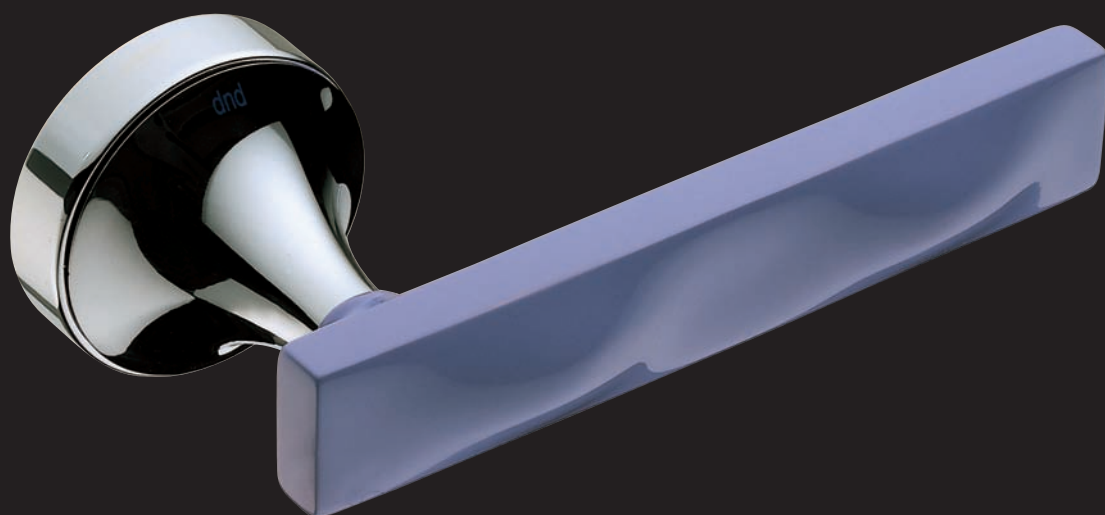

DI MANO IN MANO



BL 16 - PVD

FINITURE / FINISHES



AC



ACS



ANS



PVD INOX

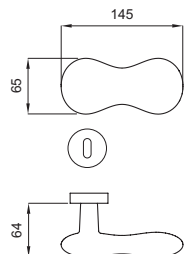

**BL 16**  
maniglia su rosetta e bocchetta  
52 mm  
door handle on rose and escutcheon  
52 mm

FINITURE / FINISHES  
AC - ACS - ANS - PVD - PVD INOX



K1 - K2 - K3 - AT

# BLIP

Design: Karim Rashid



DI MANO IN MANO

# BLIP COLOR

Design: Karim Rashid

alluminio - aluminium



BL 16 - K3

## FINITURE / FINISHES



K1



K2



K3



AT

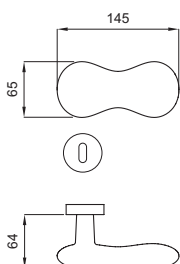

**BL 16**  
maniglia su rosetta e bocchetta  
52 mm  
door handle on rose and escutcheon  
52 mm



FINITURE / FINISHES  
K1 - K2 - K3 - AT

70

# BLIP COLOR

Design: Karim Rashid

dnd  
diffusione nuova design



DI MANO IN MANO



**HV 15 - OLV+PA**

FINITURE / FINISHES



**OLV+PA**



**OCS+PA**



**OC+NA**



**OCS+NA**



**OC+PO**



**OCS+PO**

**PELLE DI PRIMA QUALITA' "PIENO FIORE"  
FIRST QUALITY LEATHER**

FINITURE / FINISHES

OLV+PA - OCS+PA - OC+NA - OCS+NA - OC+PO - OCS+PO

72

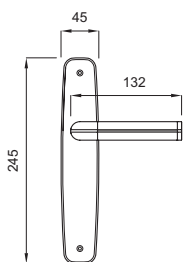

**HV 10**  
maniglia su placca  
door handle on plate

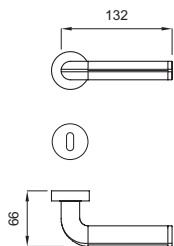

**HV 15**  
maniglia su rosetta e bocchetta 45 mm  
door handle on rose and escutcheon  
45 mm

**HV 16**  
maniglia su rosetta e bocchetta 52 mm  
door handle on rose and escutcheon  
52 mm

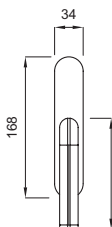

**HV 20**  
cremonese con meccanismo  
window handle with mechanism

**HV 21**  
martellina con meccanismo e q. 7x45 mm  
window handle with mechanism  
and 7x45 mm spindle

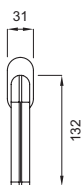

**HV 22**  
martellina DK  
DK window handle

# HAVANA

Design: Studio Hot Lab

dnd  
diffusione nuova design

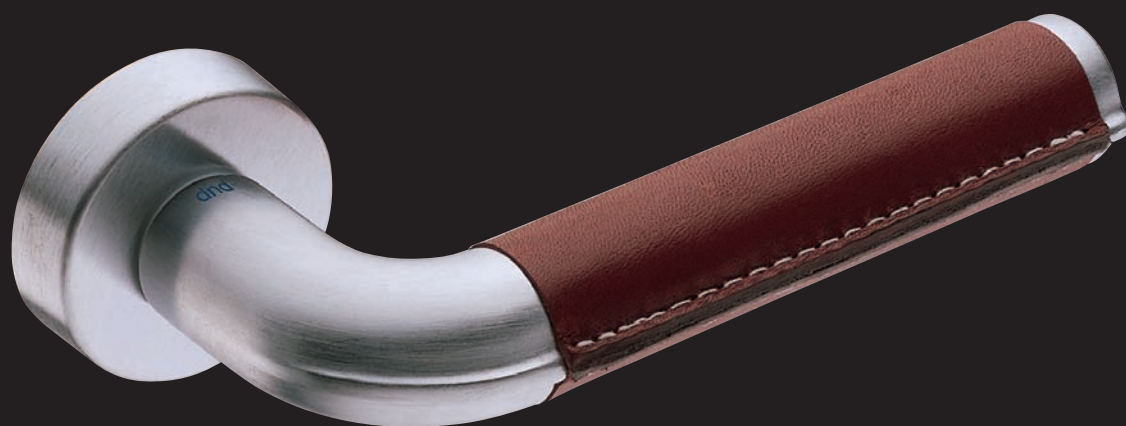

DI MANO IN MANO



**DO 15 OLV**

FINITURE / FINISHES



**OS**



**OC**



**OCS**



**ONS**



**PVD**

FINITURE / FINISHES

OLV - OS - OC - OCS - ONS - PVD - PVD INOX

74

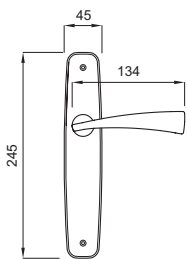

**DO 10**  
maniglia su placca  
door handle on plate

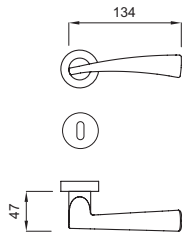

**DO 15**  
maniglia su rosetta e bocchetta 45 mm  
door handle on rose and escutcheon  
45 mm

**DO 16**  
maniglia su rosetta e bocchetta 52 mm  
door handle on rose and escutcheon  
52 mm

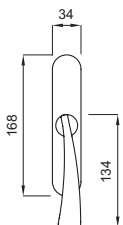

**DO 20**  
cremonese con meccanismo  
window handle with mechanism

**DO 21**  
martellina con meccanismo e q. 7x45 mm  
window handle with mechanism  
and 7x45 mm spindle

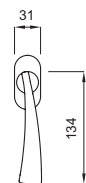

**DO 22**  
martellina DK  
DK window handle

# DOLCE

Design: Mauro Ronchi

dnd  
diffusione nuova design



DI MANO IN MANO

# DOLCE 02

Design: Mauro Ronchi

ottone stampato a caldo - hot stamped brass

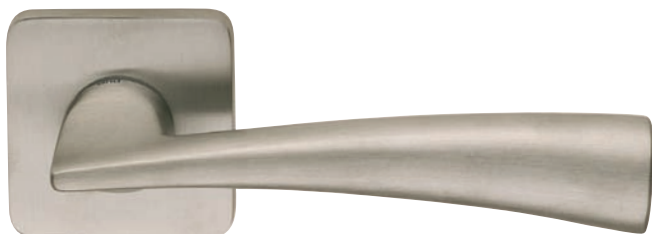

**DO 18 ONS**

## FINITURE / FINISHES



**OLV**



**OS**



**OC**



**OCS**



**PVD** 



**PVD INOX** 

FINITURE / FINISHES  
OLV - OS - OC - OCS - ONS - PVD - PVD INOX

76

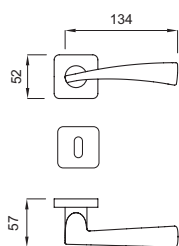

**DO 18**  
maniglia su rosetta e bocchetta quadra  
52 mm  
*door handle on square rose  
and escutcheon 52 mm*

# DOLCE 02

Design: Mauro Ronchi

dnd  
diffusione nuova design



DI MANO IN MANO



**VI 15 - OLV**

FINITURE / FINISHES



**OLV**



**OS**



**OC**



**OCS**



**ONS**



**PVD**

FINITURE / FINISHES

OLV - OS - OC - OCS - ONS - ORO - PVD - PVD INOX

78

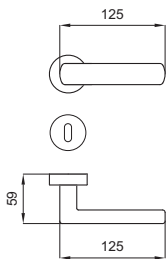

**VI 15**  
maniglia su rosetta e bocchetta 45 mm  
*door handle on rose and escutcheon  
45 mm*

**VI 16**  
maniglia su rosetta e bocchetta 52 mm  
*door handle on rose and escutcheon  
52 mm*

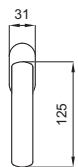

**VI 22**  
martellina DK  
*DK window handle*

# VITA

Design: Mauro Ronchi

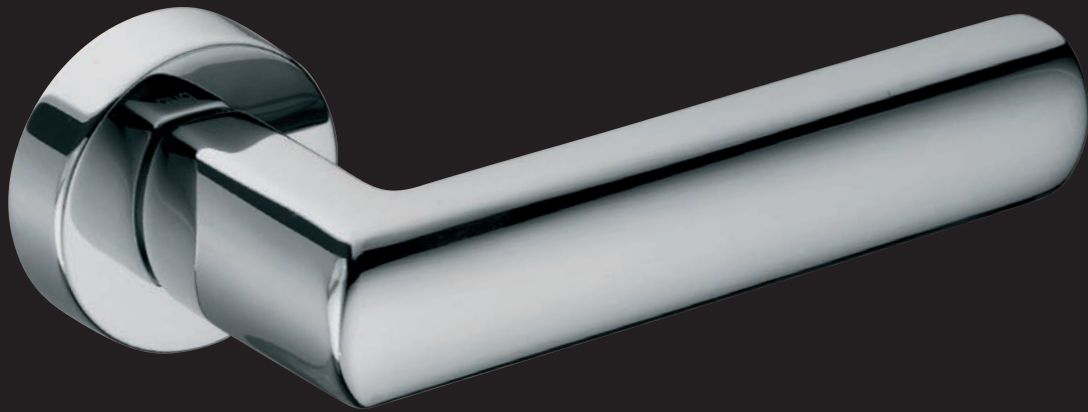

DI MANO IN MANO



**VB 15 - NNS**

FINITURE / FINISHES



**OLV**



**OLS**



**OC**



**OCS**



**CCS**



**ONS**

FINITURE / FINISHES

OLV - OLS - OC - OCS - CCS - ONS - NNS

80

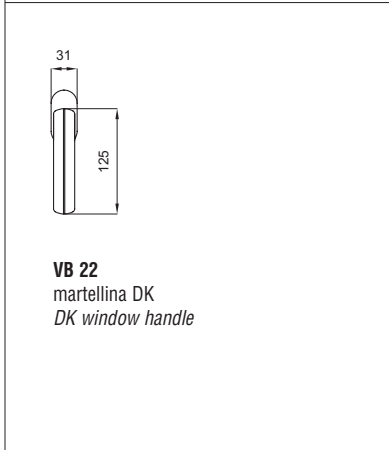
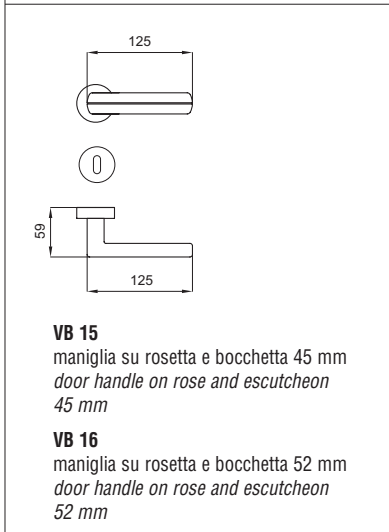

# VITA-B

Design: Mauro Ronchi

dnd  
diffusione nuova design



DI MANO IN MANO



**VC 15 - OLS**

FINITURE / FINISHES



**OLS**



**CCS**



**NNS**

FINITURE / FINISHES  
OLS - CCS - NNS

82

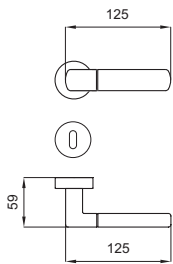

**VC 15**  
maniglia su rosetta e bocchetta 45 mm  
*door handle on rose and escutcheon  
45 mm*

**VC 16**  
maniglia su rosetta e bocchetta 52 mm  
*door handle on rose and escutcheon  
52 mm*

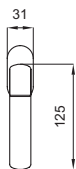

**VC 22**  
martellina DK  
*DK window handle*

# VITA-C

Design: Mauro Ronchi

dnd  
diffusione nuova design

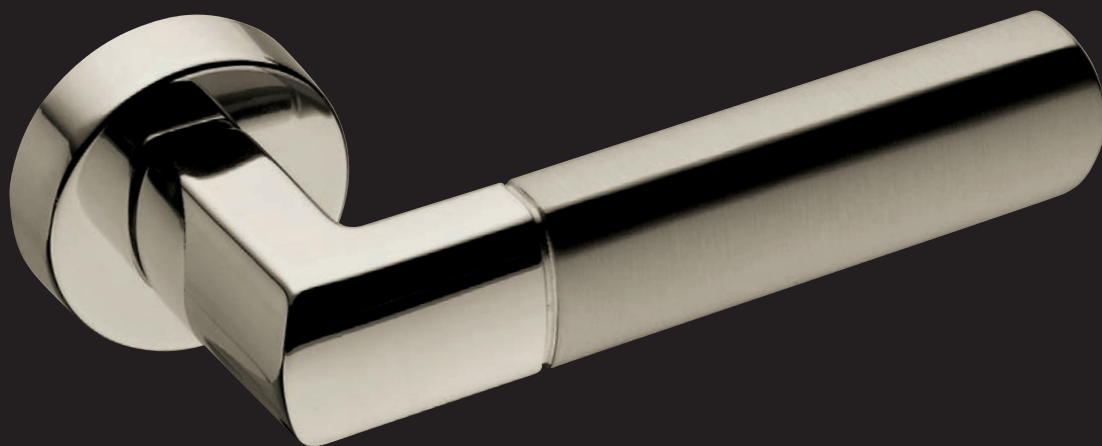

DI MANO IN MANO

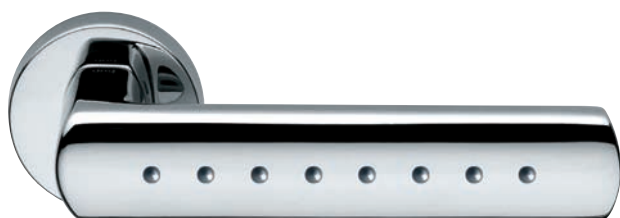

**VD 15 - OC**

FINITURE / FINISHES



**OLV**



**OS**



**OCS**



**ONS**



**PVD**



**PVD INOX**

FINITURE / FINISHES

OLV - OS - OC - OCS - ONS - ORO - PVD - PVD INOX

84

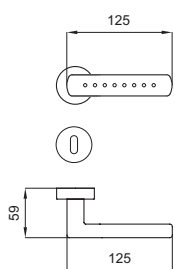

**VD 15**

maniglia su rosetta e bocchetta 45 mm  
door handle on rose and escutcheon  
45 mm

**VD 16**

maniglia su rosetta e bocchetta 52 mm  
door handle on rose and escutcheon  
52 mm

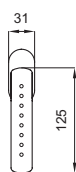

**VD 22**

martellina DK  
DK window handle

# VITA-D

Design: Mauro Ronchi

dnd  
diffusione nuova design



DI MANO IN MANO



**VI 15 - TNO**

FINITURE / FINISHES



**LPA**



**CPA**



**NPA**



**LNO**



**CNO**



**TNO**

FINITURE / FINISHES

LPA - CPA - TPA - NPA - LNO - CNO - TNO - NNO

86

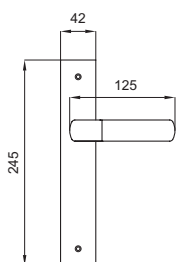

**VI 10**  
maniglia su placca Quadra  
door handle on Quadra plate

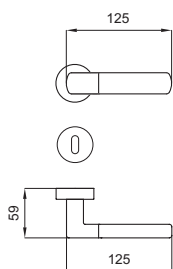

**VI 15**  
maniglia su rosetta e bocchetta 45 mm  
door handle on rose and escutcheon  
45 mm

**VI 16**  
maniglia su rosetta e bocchetta 52 mm  
door handle on rose and escutcheon  
52 mm

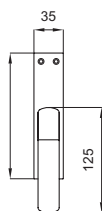

**VI 20**  
cremonese con meccanismo  
window handle with mechanism

**VI 21**  
martellina q.7 mm senza meccanismo  
window handle 7 mm square  
without mechanism

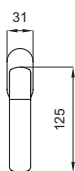

**VI 22**  
martellina DK  
DK window handle

# VITA LEGNO

Design: Mauro Ronchi

dnd  
diffusione nuova design



DI MANO IN MANO

# VITA 02

Design: Mauro Ronchi

ottone stampato a caldo - hot stamped brass

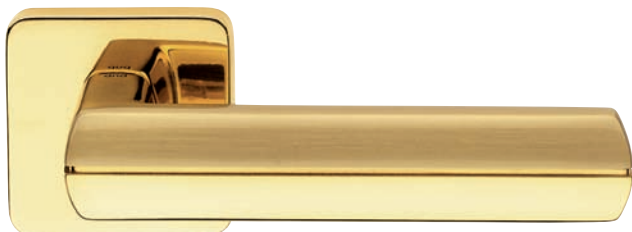

**VB 18 - OLS**

## FINITURE / FINISHES



**VITA - VI 18 OC**



**VITA-B - VB 18 CCS**



**VITA-C - VC 18 NNS**



**VITA-D - VD 18 OC**

## FINITURE / FINISHES

**VITA**  
 OLV - OS - OC - OCS - ONS - ORO - PVD - PVD INOX  
**VITA B**  
 OLV - OLS - OC - OCS - CCS - ONS - NNS  
**VITA C**  
 OLS - CCS - NNS  
**VITA D**  
 OLV - OS - OC - OCS - ONS - ORO - PVD - PVD INOX

88

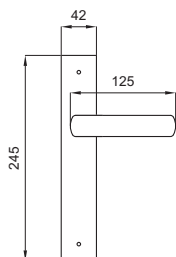

maniglia su placca quadra disponibile per:  
*door handle on square plate available for:*

**VITA VI 10**  
**VITA-B VB 10**  
**VITA-C VC 10**  
**VITA-D VD 10**

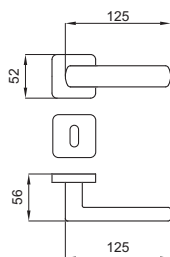

maniglia su rosetta e bocchetta quadra  
 52 mm disponibile per:  
*door handle on square rose  
 and escutcheon 52 mm available for:*

**VITA VI 18**  
**VITA-B VB 18**  
**VITA-C VC 18**  
**VITA-D VD 18**

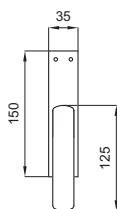

cremonese con meccanismo o martellina  
 disponibile per:  
*window handle with or without mechanism  
 available for:*

**VITA VI 20 VITA VI 21**  
**VITA-B VB 20 VITA-B VB 21**  
**VITA-C VC 20 VITA-C VC 21**  
**VITA-D VD 20 VITA-D VD 21**

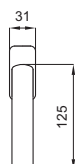

martellina DK quadro  
 disponibile per:  
*square DK window handle  
 available for:*

**VITA VI 24**  
**VITA-B VB 24**  
**VITA-C VC 24**  
**VITA-D VD 24**

# VITA 02

Design: Mauro Ronchi

dnd  
diffusione nuova design



DI MANO IN MANO

# VITA-S

Design: Mauro Ronchi

ottone stampato a caldo - hot stamped brass



**VS 15 - OLV**

## FINITURE / FINISHES

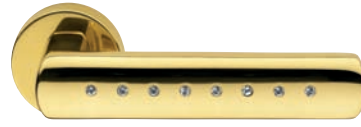

**VITA-S / VS15 OLV**



**VITA-S 02 / VS18 OC**



**VITA-S 02 / VS18 ONS**

90

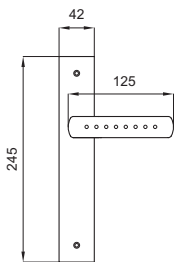

**VS 10**  
maniglia su placca Quadra  
*door handle on Quadra plate*

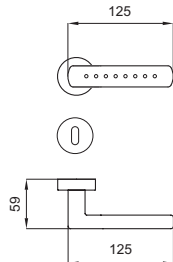

**VS 15**  
maniglia su rosetta e bocchetta 45 mm  
*door handle on rose and escutcheon 45 mm*

**VS 16**  
maniglia su rosetta e bocchetta 52 mm  
*door handle on rose and escutcheon 52 mm*

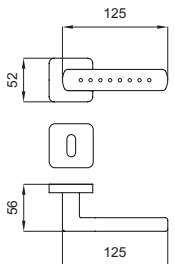

**VS 18**  
maniglia su rosetta e bocchetta quadra 52 mm  
*door handle on square rose and escutcheon 52 mm*

WITH CRYSTALLIZED™  
SWAROVSKI ELEMENTS



**CRYSTAL  
LIZED™**  
SWAROVSKI ELEMENTS

FINITURE / FINISHES  
OLV - OS - OC - OCS - ONS - ORO

# VITA-S

WITH CRYSTALLIZED™  
SWAROVSKI ELEMENTS

Design: Mauro Ronchi

dnd  
diffusione nuova design



DI MANO IN MANO

CRYSTAL  
LIZED™  
SWAROVSKI ELEMENTS

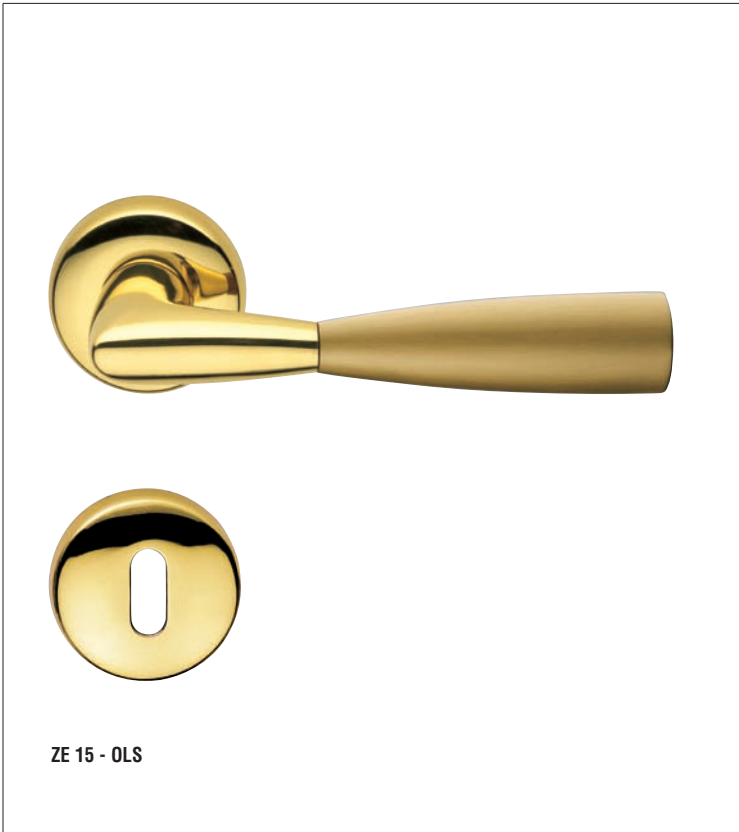

**ZE 15 - OLS**

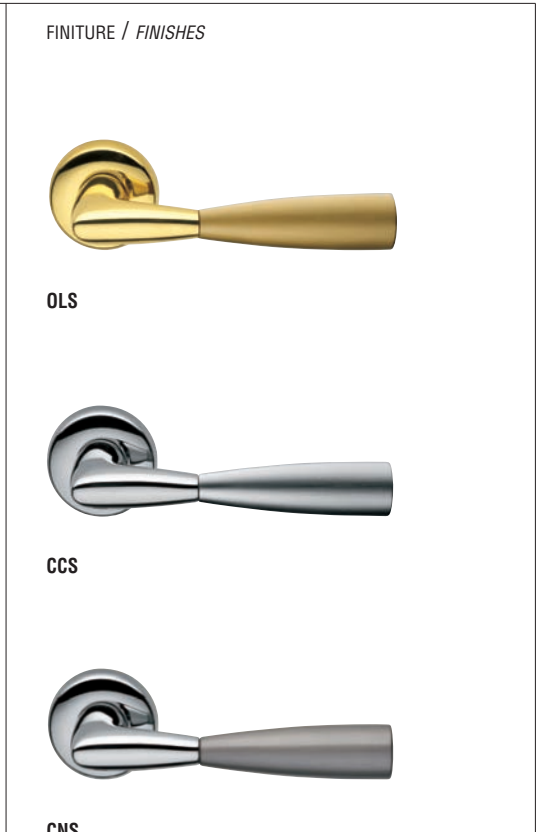

92

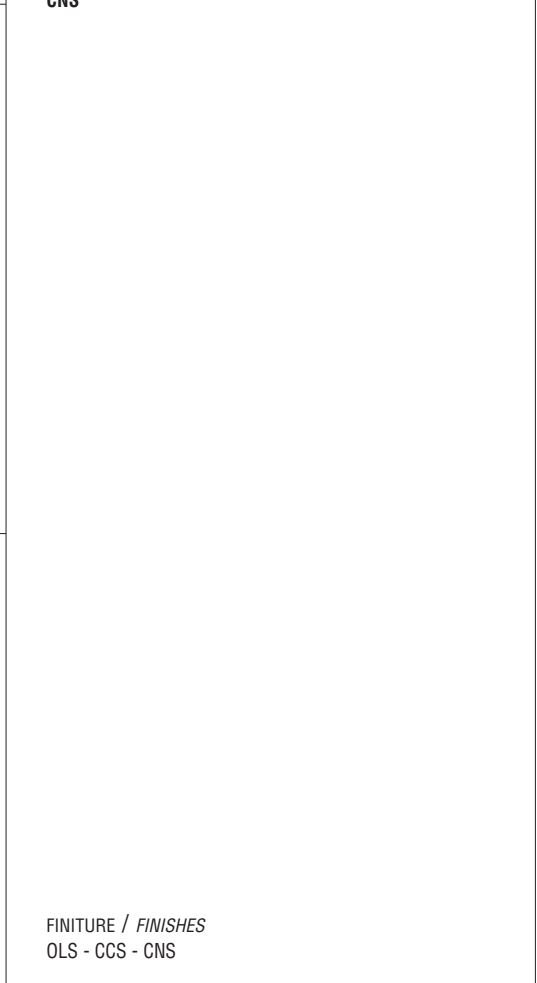
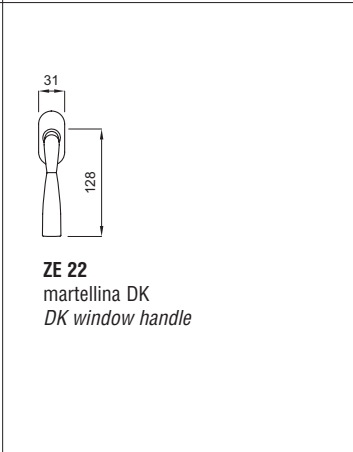
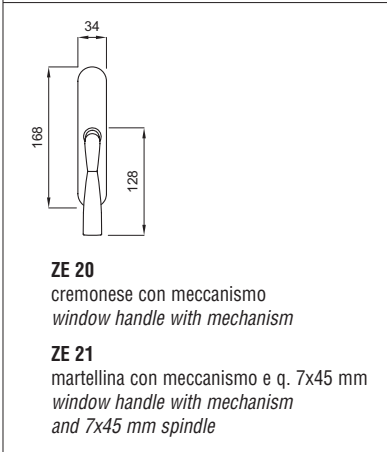
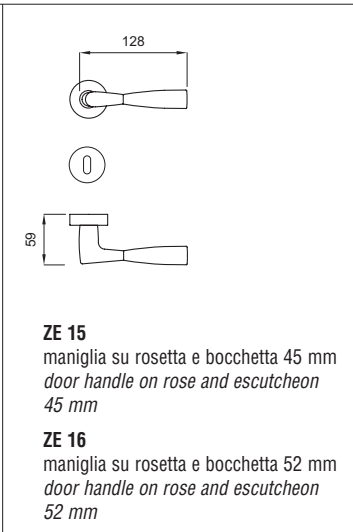
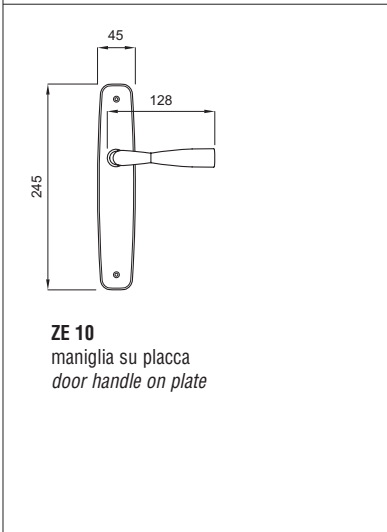

# ZEN

Design: Mauro Ronchi

dnd  
diffusione nuova design

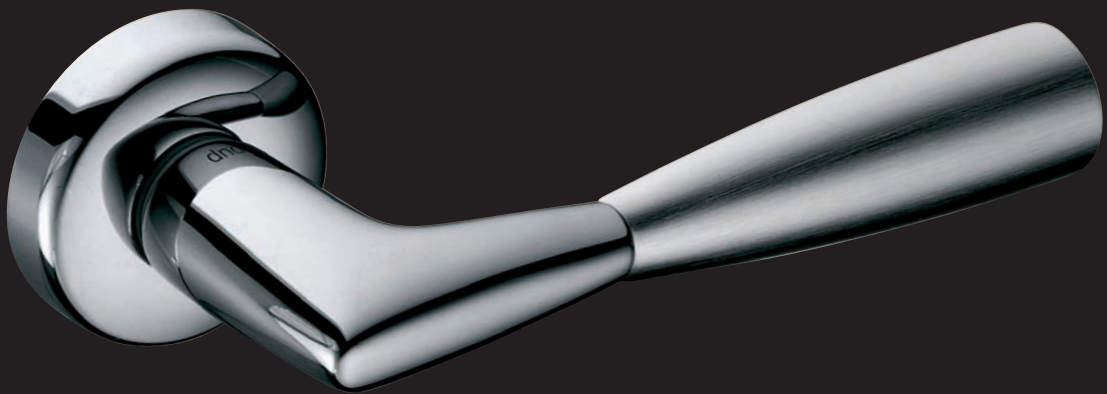

DI MANO IN MANO

# ZEN LEGNO

Design: Mauro Ronchi

ottone stampato a caldo - hot stamped brass



**ZE 15 - LPA**

## FINITURE / FINISHES



**CPA**



**TPA**



**NPA**



**LNO**



**CNO**



**TNO**

## FINITURE / FINISHES

LPA - CPA - TPA - NPA - LNO - CNO - TNO - NNO

94

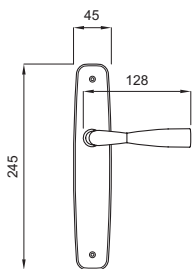

**ZE 10**  
maniglia su placca  
*door handle on plate*

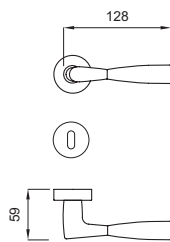

**ZE 15**  
maniglia su rosetta e bocchetta 45 mm  
*door handle on rose and escutcheon 45 mm*

**ZE 16**  
maniglia su rosetta e bocchetta 52 mm  
*door handle on rose and escutcheon 52 mm*

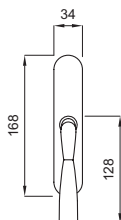

**ZE 20**  
cremonese con meccanismo  
*window handle with mechanism*

**ZE 21**  
martellina con meccanismo e q. 7x45 mm  
*window handle with mechanism and 7x45 mm spindle*

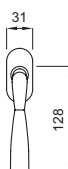

**ZE 22**  
martellina DK  
*DK window handle*

# ZEN LEGNO

Design: Mauro Ronchi

dnd  
diffusione nuova design



DI MANO IN MANO



**LO 15 - OCS**

FINITURE / FINISHES



**OLV**



**OS**



**OC**



**ONS**



**PVD**



**PVD INOX**

FINITURE / FINISHES

OLV - OS - OC - OCS - ONS - PVD - PVD INOX

96

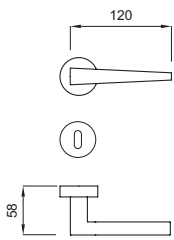

**LO 15**

maniglia su rosetta e bocchetta 45 mm  
door handle on rose and escutcheon  
45 mm

**LO 16**

maniglia su rosetta e bocchetta 52 mm  
door handle on rose and escutcheon  
52 mm

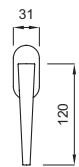

**LO 22**

martellina DK  
DK window handle

# LOGO

Design: Mauro Ronchi

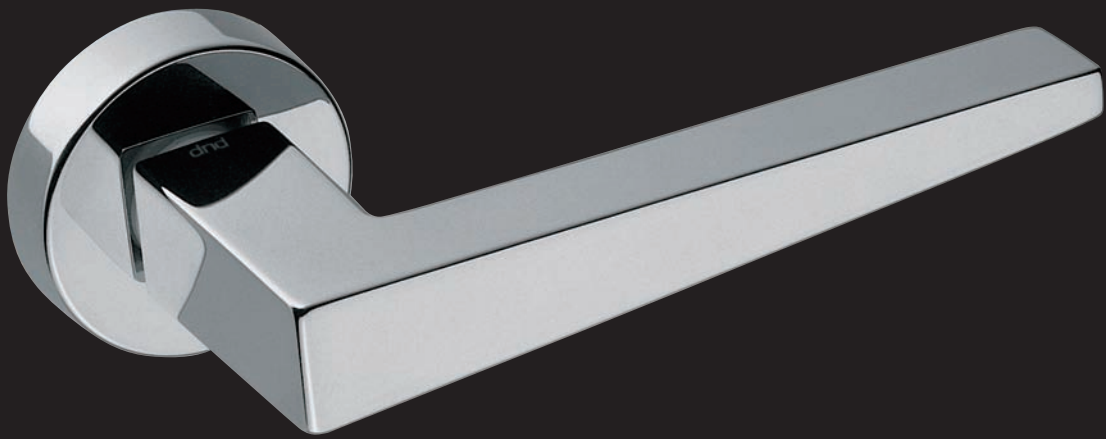

DI MANO IN MANO

# LOGO-B

Design: Mauro Ronchi

ottone stampato a caldo - hot stamped brass



**LB 15 - OLS**

## FINITURE / FINISHES



**OLS**



**CCS**



**NNS**

98

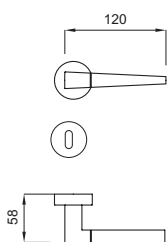

### **LB 15**

maniglia su rosetta e bocchetta 45 mm  
*door handle on rose and escutcheon  
45 mm*

### **LB 16**

maniglia su rosetta e bocchetta 52 mm  
*door handle on rose and escutcheon  
52 mm*

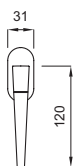

### **LB 22**

martellina DK  
*DK window handle*

## FINITURE / FINISHES

OLS - CCS - NNS

# LOGO-B

Design: Mauro Ronchi

dnd  
diffusione nuova design

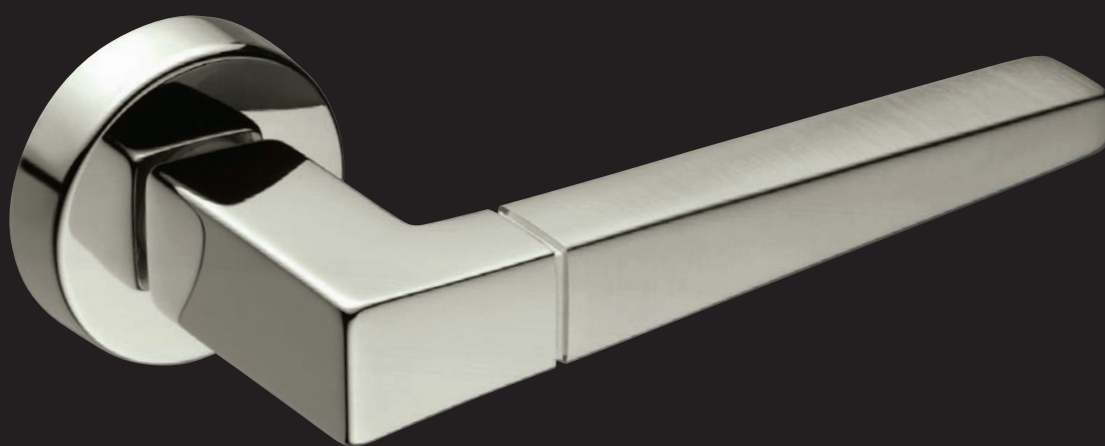

DI MANO IN MANO

# LOGO 02

Design: Mauro Ronchi

ottone stampato a caldo - hot stamped brass

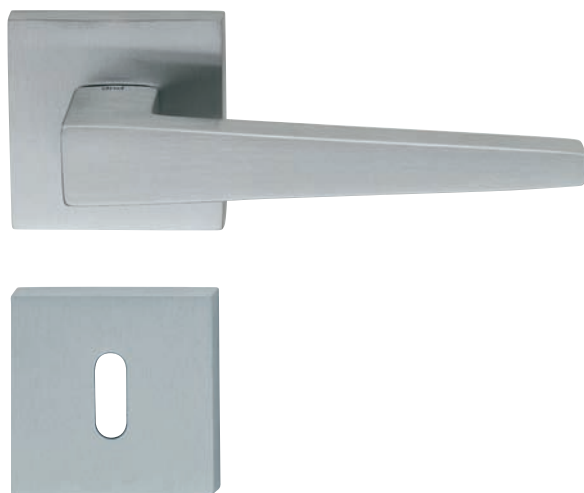

**LO - 18 - CCS**

## FINITURE / FINISHES



**LOGO - LO 18 OLV**

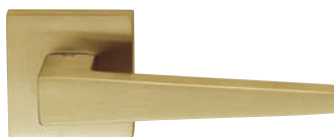

**LOGO - LO 18 OS**



**LOGO - LO 18 OC**



**LOGO-B - LB 18 OLS**



**LOGO-B - LB 18 CCS**



**LOGO-B - LB 18 NNS**

## FINITURE / FINISHES

**LOGO**  
OLV - OS - OC - OCS - ONS - PVD - PVD INOX  
**LOGO B**  
OLS - CCS - NNS

100

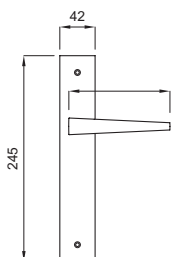

maniglia su placca quadra disponibile per:  
*door handle on square plate available for:*

**LOGO LO 10**  
**LOGO-B LB 10**

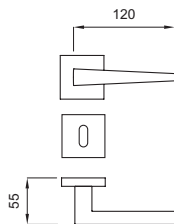

maniglia su rosetta e bocchetta quadra  
52 mm disponibile per:  
*door handle on square rose  
and escutcheon 52 mm available for:*

**LOGO LO 18**  
**LOGO-B LB 18**

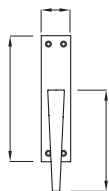

cremonese con meccanismo o martellina  
disponibile per:  
*window handle with or without mechanism  
available for:*

**LOGO LO 20**    **LOGO LO 21**  
**LOGO-B LB 20**    **LOGO-B LB 21**

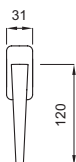

martellina DK quadro  
disponibile per:  
*square DK window handle  
available for:*

**LOGO LO 24**  
**LOGO-B LB 24**

# LOGO 02

Design: Mauro Ronchi

dnd  
diffusione nuova design

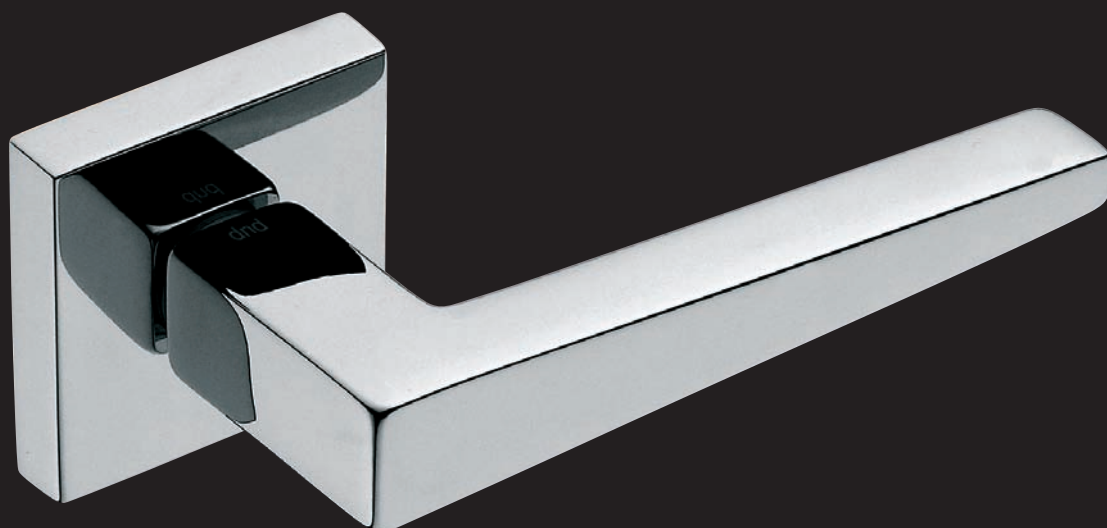

DI MANO IN MANO



FINITURE / FINISHES



**OLV**



**OS**



**OC**



**ONS**



**PVD**



**PVD INOX**

FINITURE / FINISHES  
OLV - OS - OC - OCS - ONS - PVD - PVD INOX

102

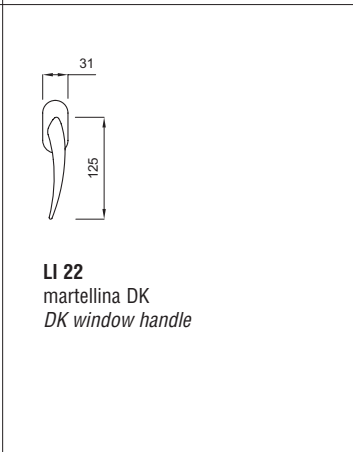
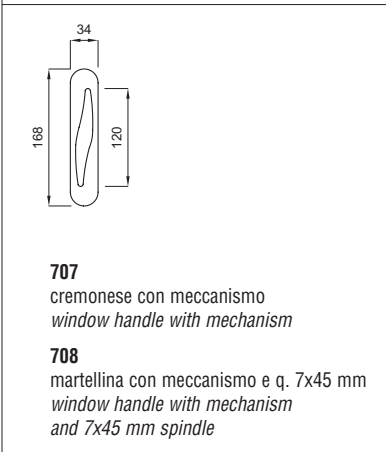
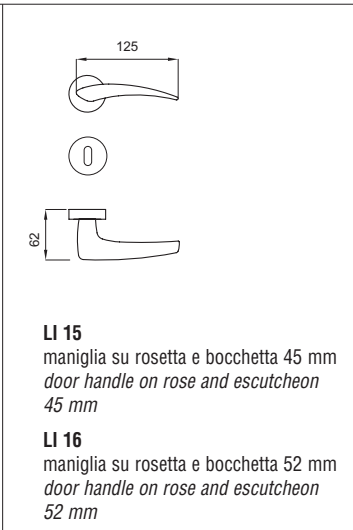
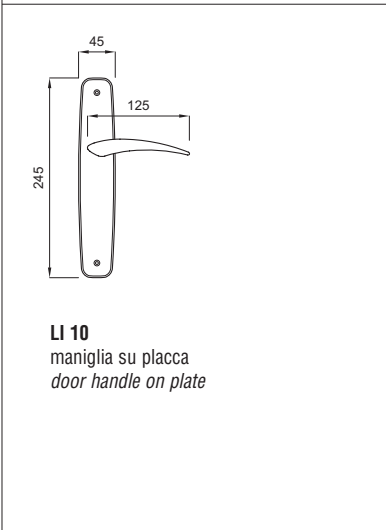

# LINEAR

Design: Mauro Ronchi

dnd  
diffusione nuova design



DI MANO IN MANO

# LINEAR 02

Design: Mauro Ronchi

ottone stampato a caldo - hot stamped brass



LI 18 - OC

FINITURE / FINISHES



OLV



OS



OCS



ONS



PVD



PVD INOX

FINITURE / FINISHES  
OLV - OS - OC - OCS - ONS - PVD - PVD INOX

104

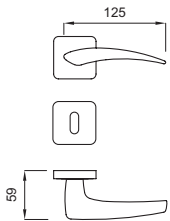

**LI 18**  
maniglia su rosetta e bocchetta quadra  
52 mm  
door handle on square rose  
and escutcheon 52 mm

# LINEAR 02

Design: Mauro Ronchi

dnd  
diffusione nuova design

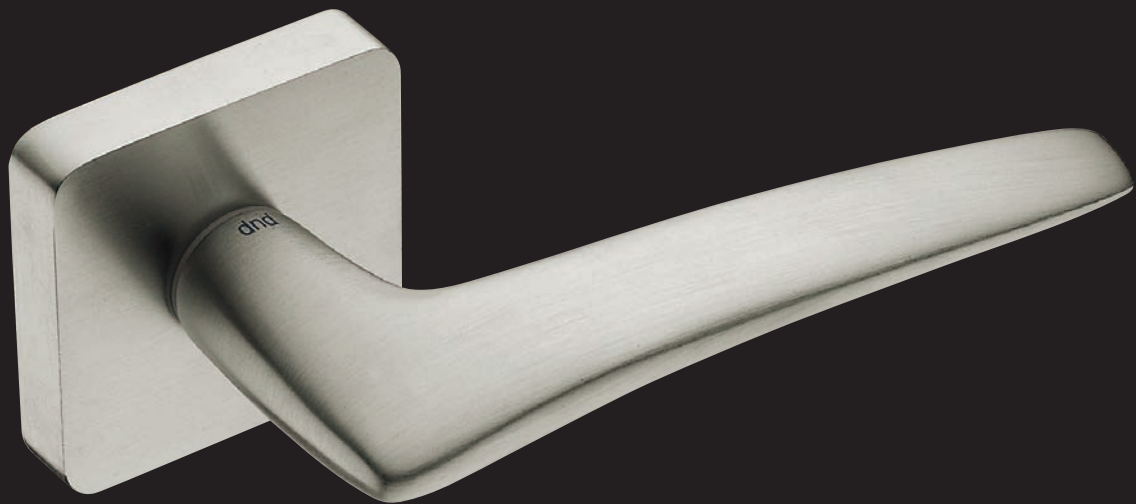

DI MANO IN MANO

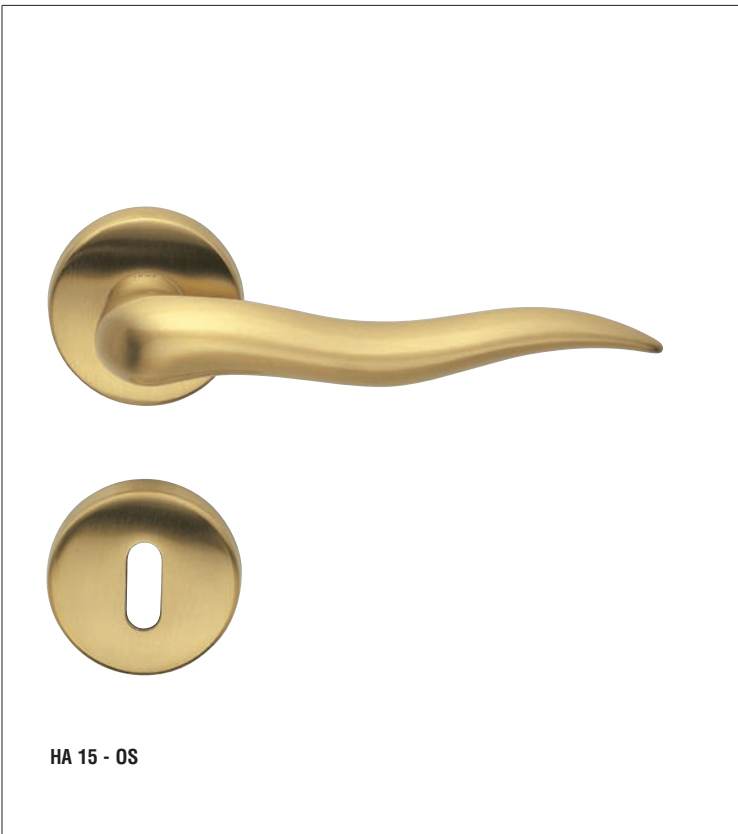

FINITURE / FINISHES



**OLV**



**OC**



**OCS**



**ONS**



**ORO**

FINITURE / FINISHES

OLV - OS - OC - OCS - ONS - ORO

106

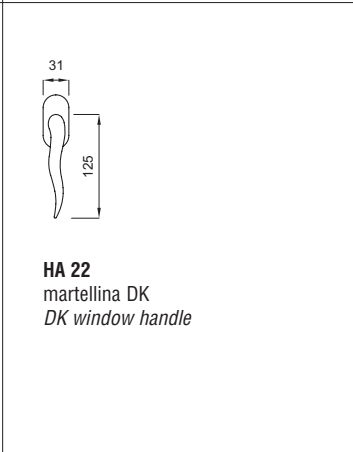
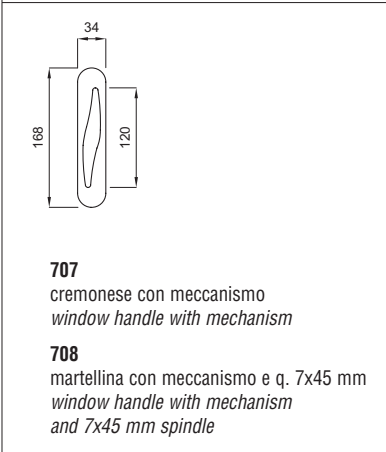
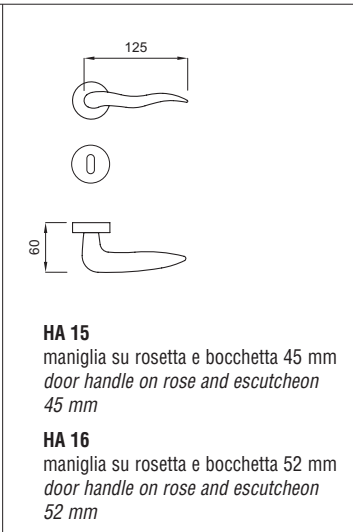
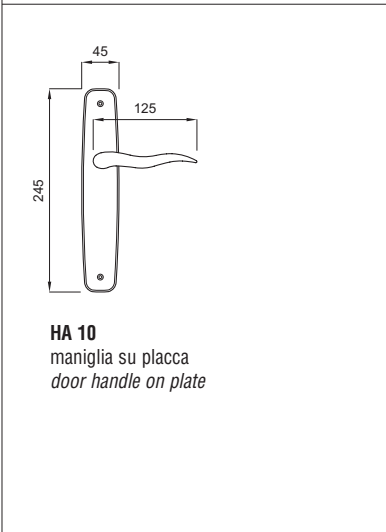

# HALLEY

Design: Mauro Ronchi

dnd  
diffusione nuova design



DI MANO IN MANO



**FL 15 - OLV**

FINITURE / FINISHES



**OC**



**OCS**



**ONS**



**ORO**



**PVD**



**PVD INOX**

FINITURE / FINISHES

OLV - OS - OC - OCS - ONS - ORO - PVD - PVD INOX

108

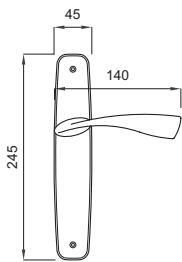

**FL 10**  
maniglia su placca  
door handle on plate

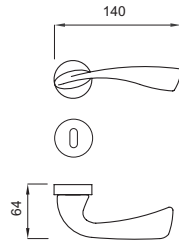

**FL 15**  
maniglia su rosetta e bocchetta 45 mm  
door handle on rose and escutcheon  
45 mm

**FL 16**  
maniglia su rosetta e bocchetta 52 mm  
door handle on rose and escutcheon  
52 mm

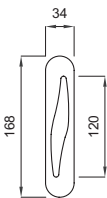

**707**  
cremonese con meccanismo  
window handle with mechanism

**708**  
martellina con meccanismo e q. 7x45 mm  
window handle with mechanism  
and 7x45 mm spindle



**FL 22**  
martellina DK  
DK window handle

# FLUO'

Design: Mauro Ronchi

dnd  
diffusione nuova design



DI MANO IN MANO



**GO 15 - OCS**

FINITURE / FINISHES



**OLV**



**OC**



**ONS**



**ORO**



**PVD**



**PVD INOX**

FINITURE / FINISHES  
OLV - OS - OC - OCS - ONS - ORO - PVD - PVD INOX

110

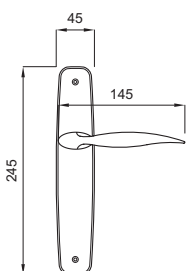

**GO 10**  
maniglia su placca  
door handle on plate

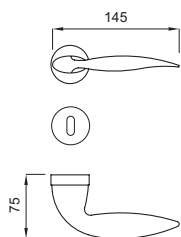

**GO 15**  
maniglia su rosetta e bocchetta 45 mm  
door handle on rose and escutcheon  
45 mm

**GO 16**  
maniglia su rosetta e bocchetta 52 mm  
door handle on rose and escutcheon  
52 mm

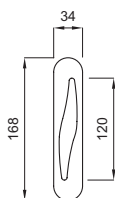

**707**  
cremonese con meccanismo  
window handle with mechanism

**708**  
martellina con meccanismo e q. 7x45 mm  
window handle with mechanism  
and 7x45 mm spindle

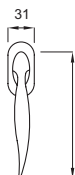

**GO 22**  
martellina DK  
DK window handle

# GO

Design: Mauro Ronchi

dnd  
diffusione nuova design



DI MANO IN MANO



AR 15 - PVD

FINITURE / FINISHES



OLV



OS



OC



OCS



ONS



ORO

FINITURE / FINISHES

OLV - OS - OC - OCS - ONS - ORO - PVD - PVD INOX

112

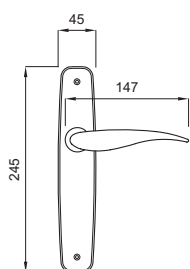

**AR 10**  
maniglia su placca  
door handle on plate

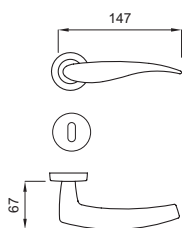

**AR 15**  
maniglia su rosetta e bocchetta 45 mm  
door handle on rose and escutcheon  
45 mm

**AR 16**  
maniglia su rosetta e bocchetta 52 mm  
door handle on rose and escutcheon  
52 mm

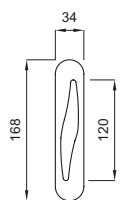

**707**  
cremonese con meccanismo  
window handle with mechanism

**708**  
martellina con meccanismo e q. 7x45 mm  
window handle with mechanism  
and 7x45 mm spindle

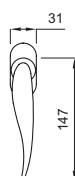

**AR 22**  
martellina DK  
DK window handle

# ART

Design: Mauro Ronchi



DI MANO IN MANO



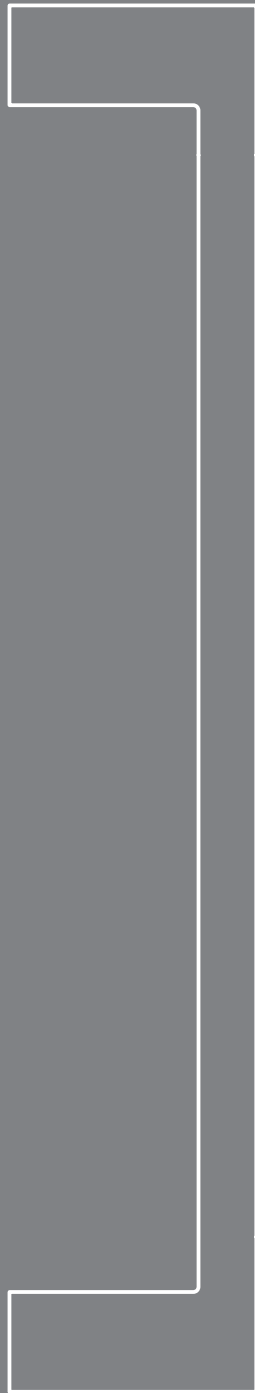

DI MANO IN MANO

M A N I G L I O N I - P U L L H A N D L E S

116



**LO 26 - OLV**

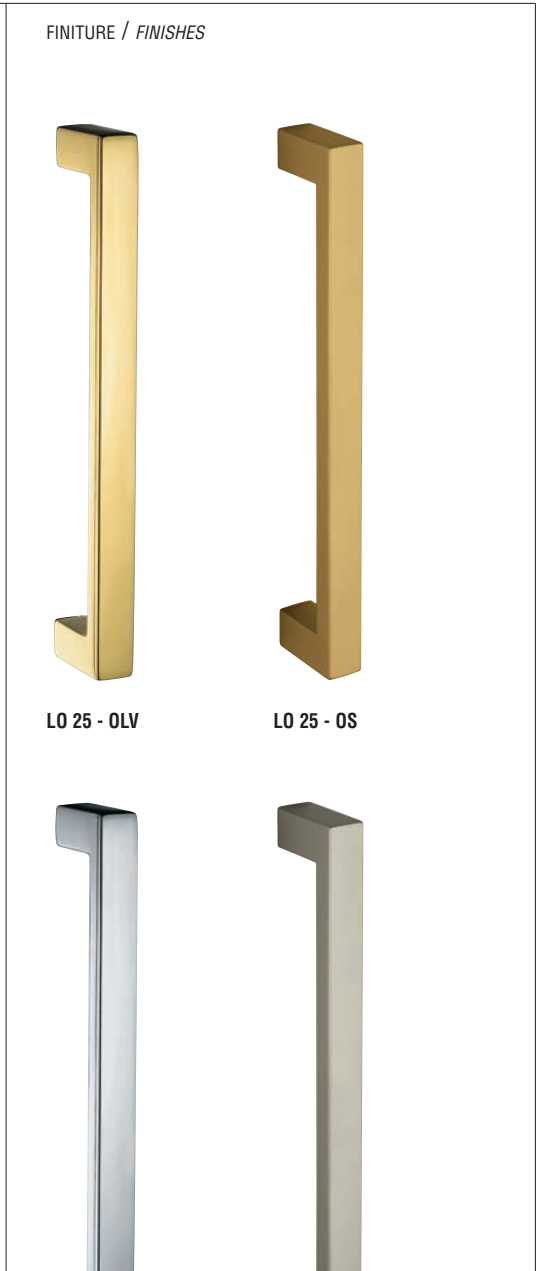

**LO 25 - OLV**

**LO 25 - OS**

**LO 25 - OC**

**LO 25 - ONS**

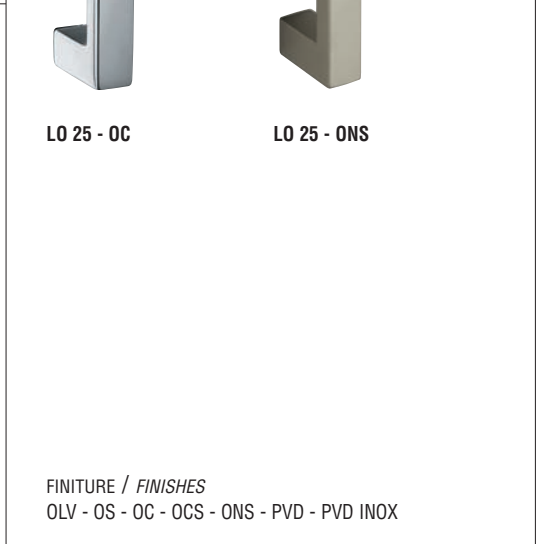
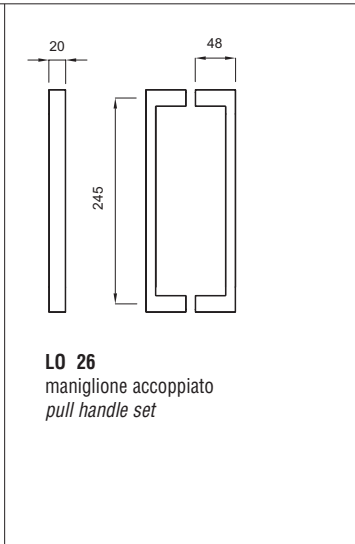
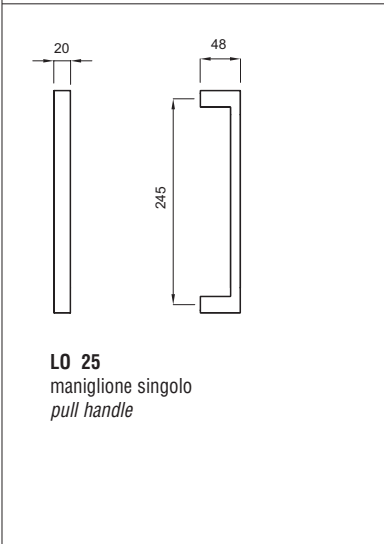

# LOGO

Design: Mauro Ronchi



DI MANO IN MANO

# LOGO-B

Design: Mauro Ronchi

ottone stampato a caldo - hot stamped brass



LB 26 - CCS

## FINITURE / FINISHES



LB 25 - OLS



LB 25 - CCS

118

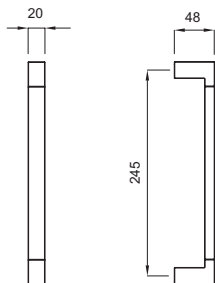

LB 25  
maniglione singolo  
pull handle

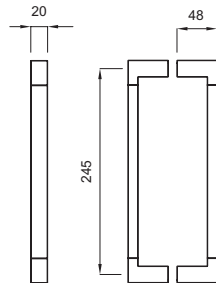

LB 26  
maniglione accoppiato  
pull handle set

FINITURE / FINISHES  
OLS - CCS - NNS

# LOGO-B

Design: Mauro Ronchi

dnd  
diffusione nuova design



DI MANO IN MANO

# LINEAR

Design: Mauro Ronchi

ottone stampato a caldo - hot stamped brass



120



LI 26 - OLV

## FINITURE / FINISHES



OS



OC



OCS



ONS

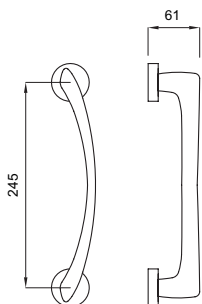

**LI 25**  
maniglione singolo con rosette  
*pull handle with roses*

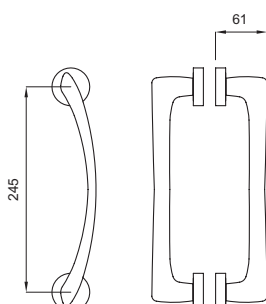

**LI 26**  
maniglione accoppiato con rosette  
*pull handle set with roses*

FINITURE / FINISHES  
OLV - OS - OC - OCS - ONS - PVD - PVD INOX

# LINEAR

Design: Mauro Ronchi

dnd  
diffusione nuova design



DI MANO IN MANO

# LINEAR

Design: Mauro Ronchi

ottone stampato a caldo - hot stamped brass



122



LI 28 - OS

## FINITURE / FINISHES



OS



OC



OCS



ONS

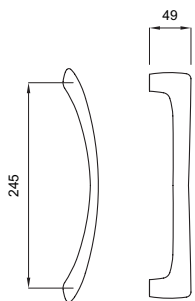

LI 27  
maniglione singolo senza rosette  
pull handle without roses

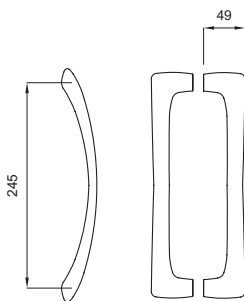

LI 28  
maniglione accoppiato senza rosette  
pull handle set without roses

FINITURE / FINISHES  
OLV - OS - OC - OCS - ONS - PVD - PVD INOX

# LINEAR

Design: Mauro Ronchi

dnd  
diffusione nuova design

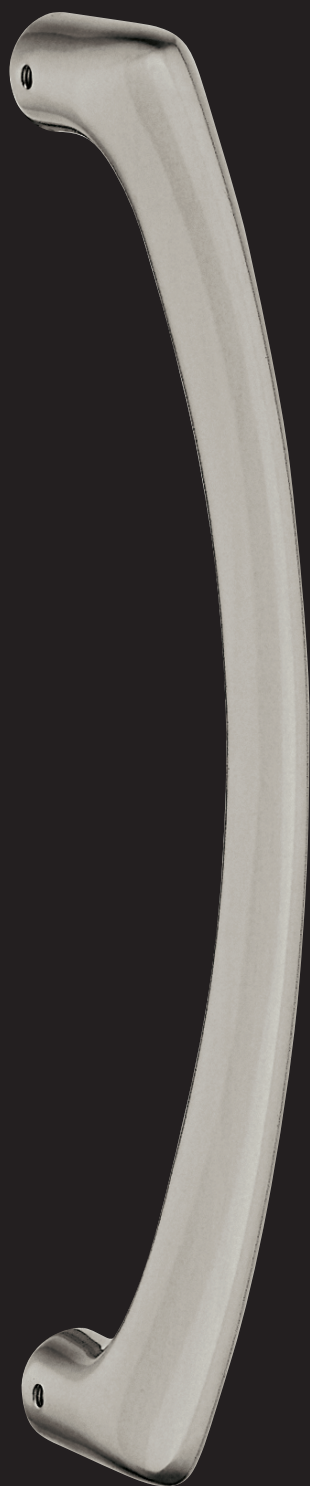

DI MANO IN MANO



AR 26 - OC

FINITURE / FINISHES



OLV



OS



OC



ONS

FINITURE / FINISHES

OLV - OS - OC - OCS - ONS - PVD - PVD INOX

124

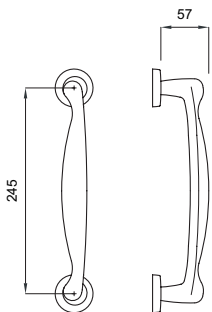

**AR 25**  
maniglione singolo con rosette  
*pull handle with roses*

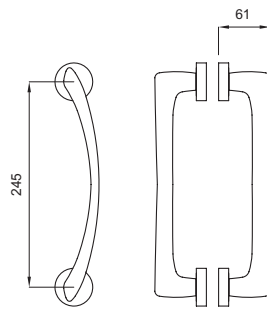

**AR 26**  
maniglione accoppiato con rosette  
*pull handle set with roses*

# ART

Design: Mauro Ronchi

dnd  
diffusione nuova design



DI MANO IN MANO

126



**AR 28 - ONS**

FINITURE / FINISHES

**OLV**                      **OS**

**OC**                              **OCS**

FINITURE / FINISHES  
 OLV - OS - OC - OCS - ONS - PVD - PVD INOX

**AR 27**  
 maniglione singolo senza rosette  
*pull handle without roses*

**AR 28**  
 maniglione accoppiato senza rosette  
*pull handle set without roses*

# ART

Design: Mauro Ronchi

dnd  
diffusione nuova design



DI MANO IN MANO

# GO

Design: Mauro Ronchi

ottone stampato a caldo - hot stamped brass

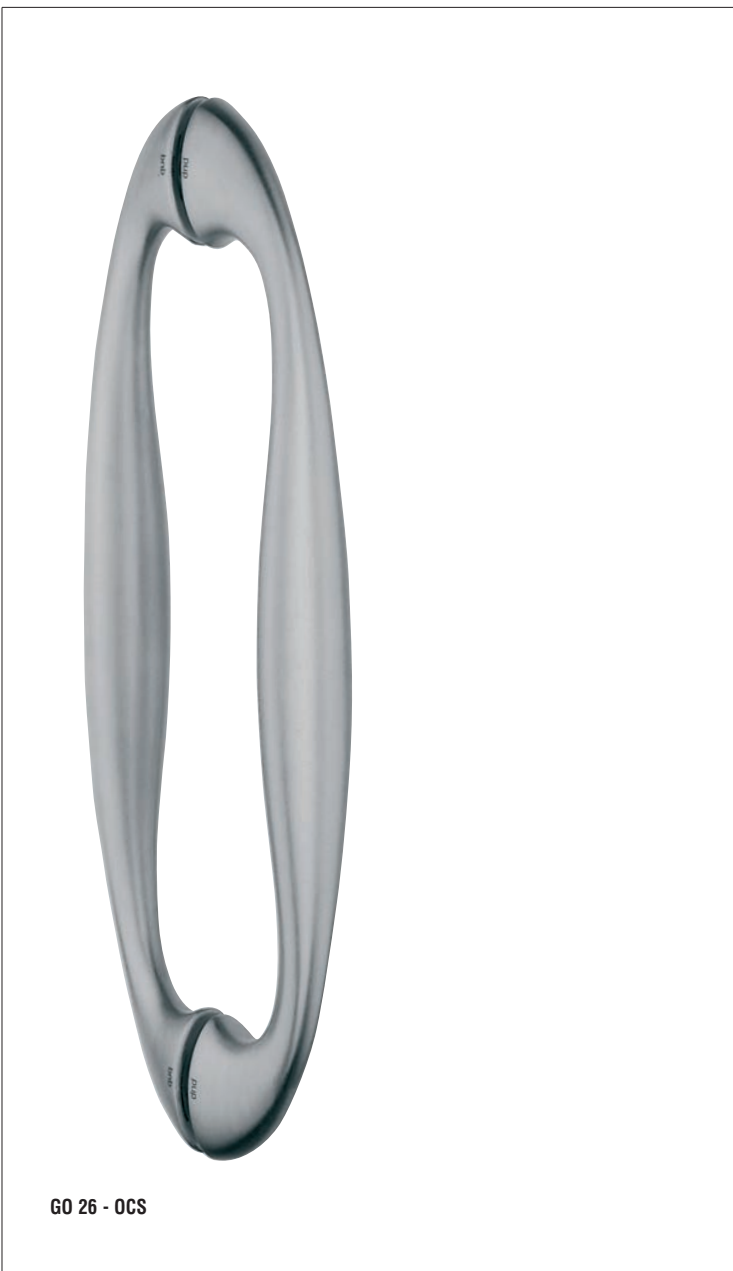

GO 26 - OCS

### FINITURE / FINISHES



OLV



OC



OCS



ONS

FINITURE / FINISHES  
OLV - OS - OC - OCS - ONS - PVD - PVD INOX

128

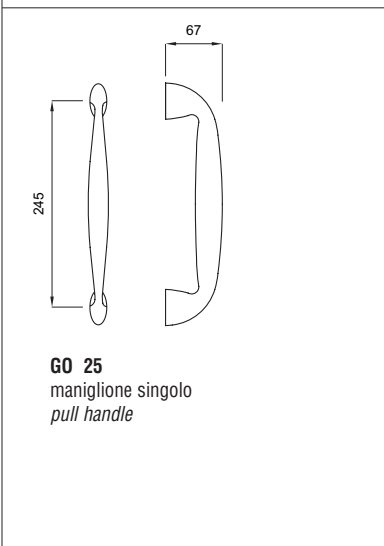

GO 25  
maniglione singolo  
pull handle

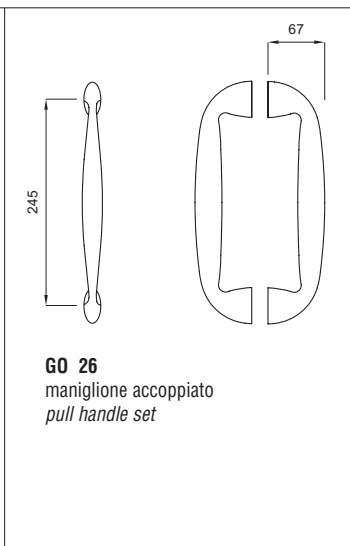

GO 26  
maniglione accoppiato  
pull handle set

# GO

Design: Mauro Ronchi



DI MANO IN MANO



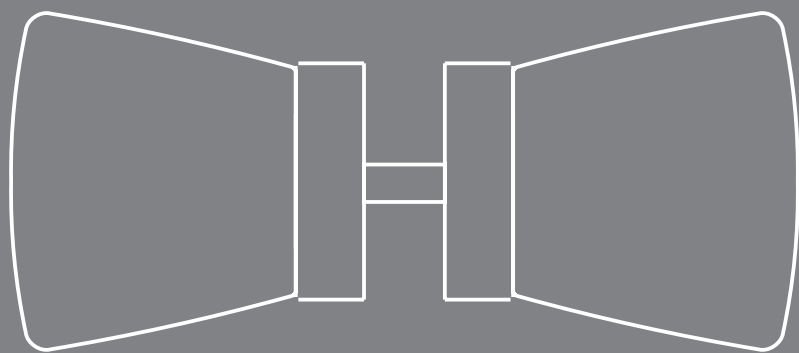

DI MANO IN MANO

P O M O L I - K N O B S

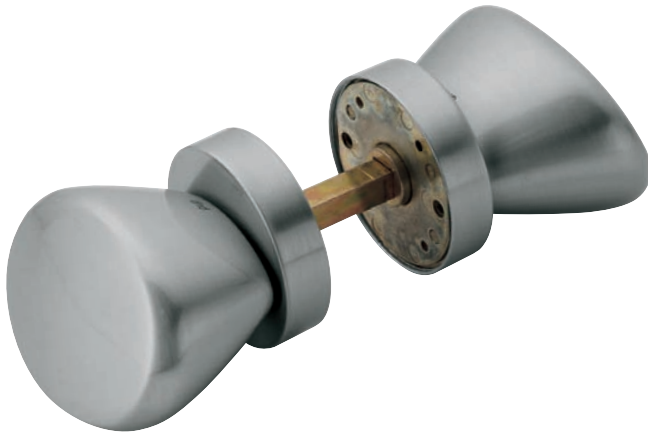

**AR 38 - OCS**

FINITURE / FINISHES



**OLV**



**OS**



**OC**



**OCS**



**ONS**



**AR 35**



**AR 40**

FINITURE / FINISHES

**AR 35 - AR 37 - AR 38**

OLV - OS - OC - OCS - ONS - PVD - PVD INOX

**AR 40**

OLV - OS - OC - OCS - ONS

132

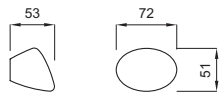

**AR 35**  
pomolo fisso senza rosetta  
*centre door knob*

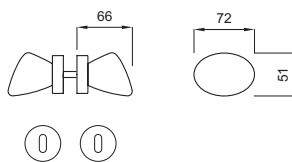

**AR 37**  
coppia pomolo su rosetta e bocchetta  
45 mm  
*mortice knob set on rose  
and escutcheon 45 mm*

**AR 38**  
coppia pomolo su rosetta e bocchetta  
52 mm  
*mortice knob set on rose  
and escutcheon 52 mm*

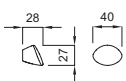

**AR 40**  
pomolino per mobili  
*furniture knob*

# ART

Design: Mauro Ronchi



DI MANO IN MANO

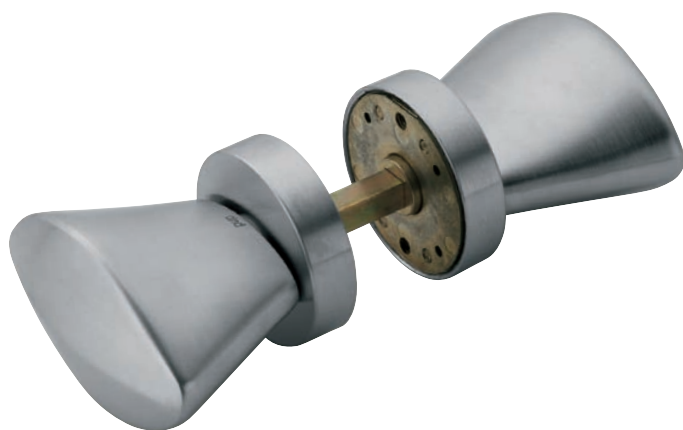

**GO 38 - OCS**

FINITURE / FINISHES



**OLV**



**OS**



**OC**



**OCS**



**ONS**



**GO 35**



**GO 40**

FINITURE / FINISHES

**GO 35 - GO 37 - GO 38**

OLV - OS - OC - OCS - ONS - PVD - PVD INOX

**GO 40**

OLV - OS - OC - OCS - ONS

134

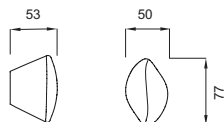

**GO 35**  
pomolo fisso senza rosetta  
centre door knob

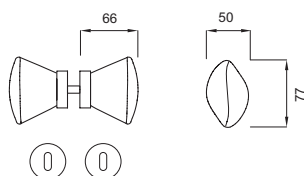

**GO 37**  
coppia pomolo su rosetta e bocchetta  
45 mm  
mortice knob set on rose  
and escutcheon 45 mm

**GO 38**  
coppia pomolo su rosetta e bocchetta  
52 mm  
mortice knob set on rose  
and escutcheon 52 mm

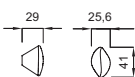

**GO 40**  
pomolino per mobili  
furniture knob

# GO

Design: Mauro Ronchi

dnd  
diffusione nuova design



DI MANO IN MANO

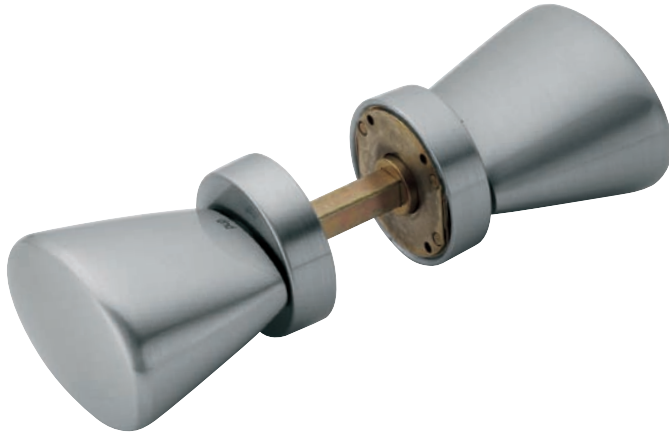

**FL 35 - OCS**

FINITURE / FINISHES



**OLV**



**OS**



**OC**



**OCS**



**ONS**



**FL 35**

**FL 40**

FINITURE / FINISHES

**FL 35 - FL 37 - FL 38**

OLV - OS - OC - OCS - ONS - PVD - PVD INOX

**FL 40**

OLV - OS - OC - OCS - ONS

136

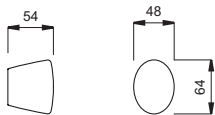

**FL 35**  
pomolo fisso senza rosetta  
centre door knob

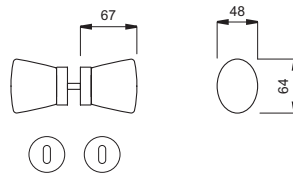

**FL 37**  
coppia pomolo su rosetta e bocchetta  
45 mm  
mortice knob set on rose  
and escutcheon 45 mm

**FL 38**  
coppia pomolo su rosetta e bocchetta  
52 mm  
mortice knob set on rose  
and escutcheon 52 mm

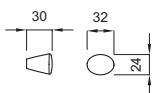

**FL 40**  
pomolino per mobili  
furniture knob

# FLUO'

Design: Mauro Ronchi

dnd  
diffusione nuova design



DI MANO IN MANO





DI MANO IN MANO

P O R T A B I T I - C O A T H A N G E R S

# MOBY

Design: Mauro Ronchi

ottone stampato a caldo - hot stamped brass



MO 100 - OC

## FINITURE / FINISHES



OLV



OS



OC



OCS

140

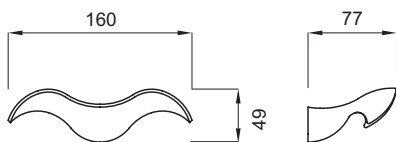

MO 100  
portabiti  
coat hanger

FINITURE / FINISHES  
OLV - OS - OC - OCS

# MOBY

Design: Mauro Ronchi

dnd  
diffusione nuova design



DI MANO IN MANO

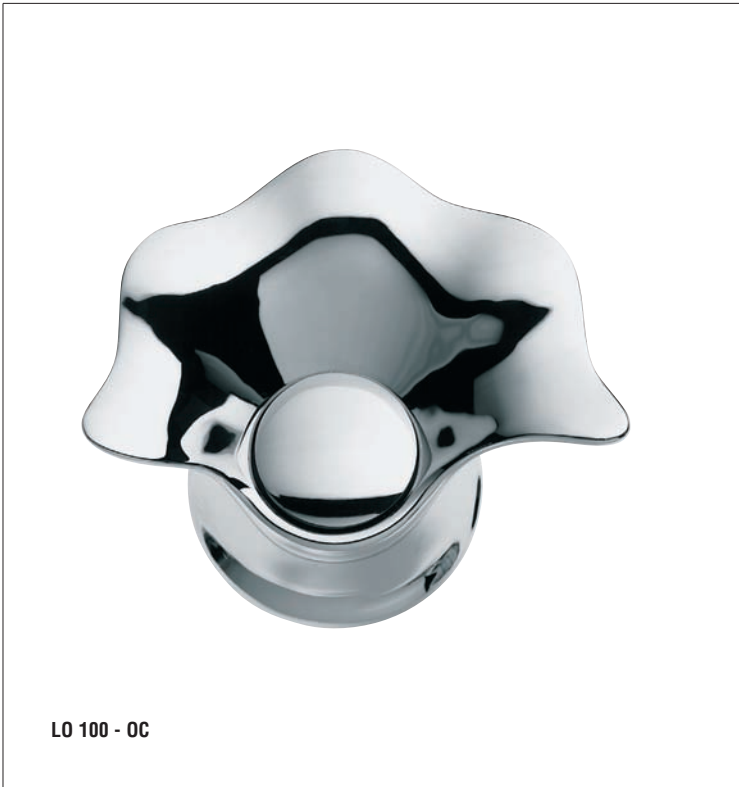

LO 100 - OC

FINITURE / FINISHES



OLV



OS



OC



OCS

142

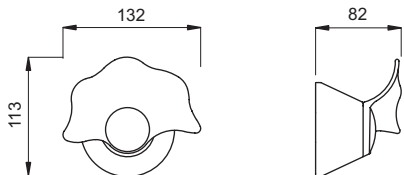
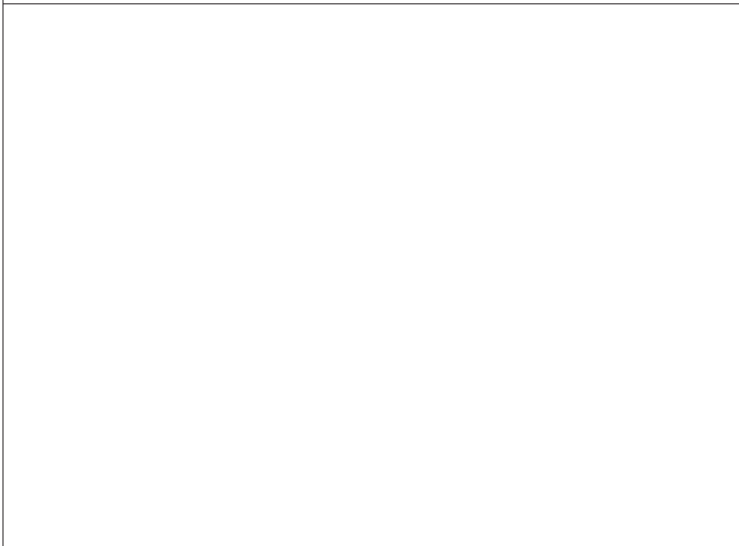

LO 100  
portabiti  
coat hanger

FINITURE / FINISHES  
OLV - OS - OC - OCS

# LOTO

Design: Mauro Ronchi

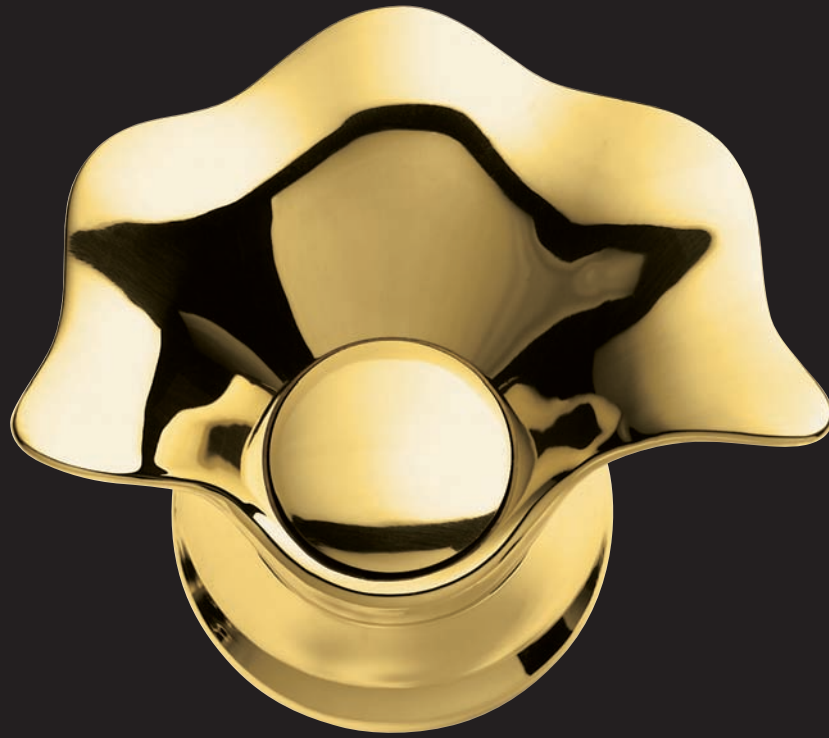

DI MANO IN MANO

# MEDUSA

Design: Mauro Ronchi

ottone stampato a caldo - hot stamped brass



ME 100 - OC

144

## FINITURE / FINISHES



OLV



OS



OC

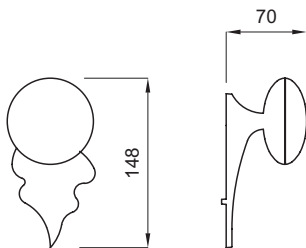

ME 100  
portabiti  
coat hanger

FINITURE / FINISHES  
OLV - OS - OC - OCS

# MEDUSA

Design: Mauro Ronchi

dnd  
diffusione nuova design



DI MANO IN MANO

# MEDUSA RIGATO

Design: Mauro Ronchi

ottone stampato a caldo - hot stamped brass



ME 101 - OC

## FINITURE / FINISHES



OLV



OS



OC

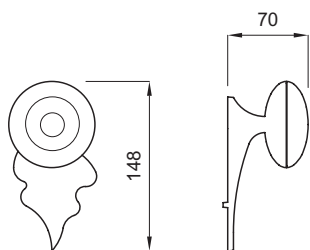

ME 101  
portabiti  
coat hanger

FINITURE / FINISHES  
OLV - OS - OC - OCS

146

# MEDUSA RIGATO

Design: Mauro Ronchi

dnd  
diffusione nuova design



DI MANO IN MANO



AL 100 - OC+RE2

FINITURE / FINISHES



AL 100 - OC+RE2



AL 101 - OC+RE2



AL 100 - OC+RE5



AL 101 - OC+RE5

148

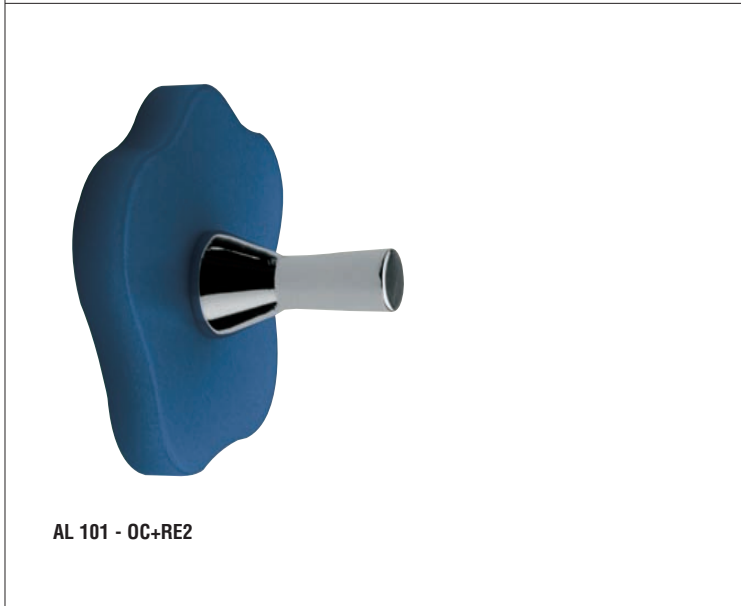

AL 101 - OC+RE2

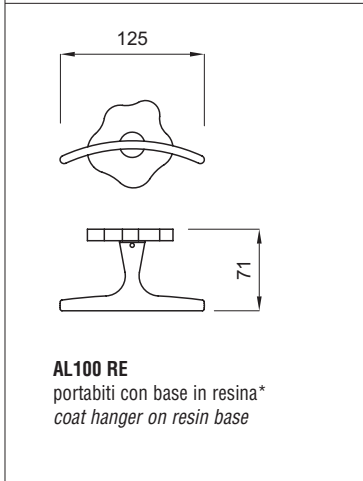

**AL100 RE**  
portabiti con base in resina\*  
coat hanger on resin base

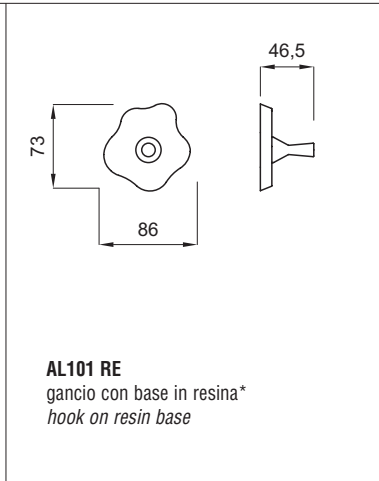

**AL101 RE**  
gancio con base in resina\*  
hook on resin base

BASE IN RESINA - RESIN BASE  
RE 2 = BLU - BLUE  
RE 5 = FUCSIA - FUCHSIA

FINITURE / FINISHES  
OC+RE2 - OC+RE5 - OCS+RE2 - OCS+RE5

# ALGA

Design: Mauro Ronchi

dnd  
diffusione nuova design

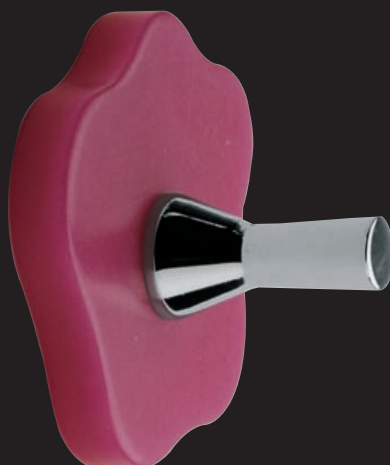

DI MANO IN MANO



AL 100 OLV



AL 101 OLV

FINITURE / FINISHES



OLV



OLV



OC



OC



OCS



OCS

150

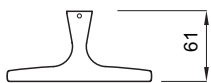
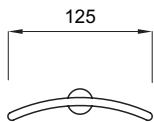

AL 100  
portabiti  
coat hanger

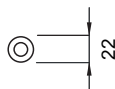

AL 101  
gancio  
hook

FINITURE / FINISHES  
OLV - OC - OCS

# ALGA

Design: Mauro Ronchi

dnd  
diffusione nuova design

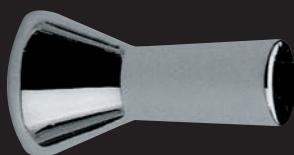

DI MANO IN MANO



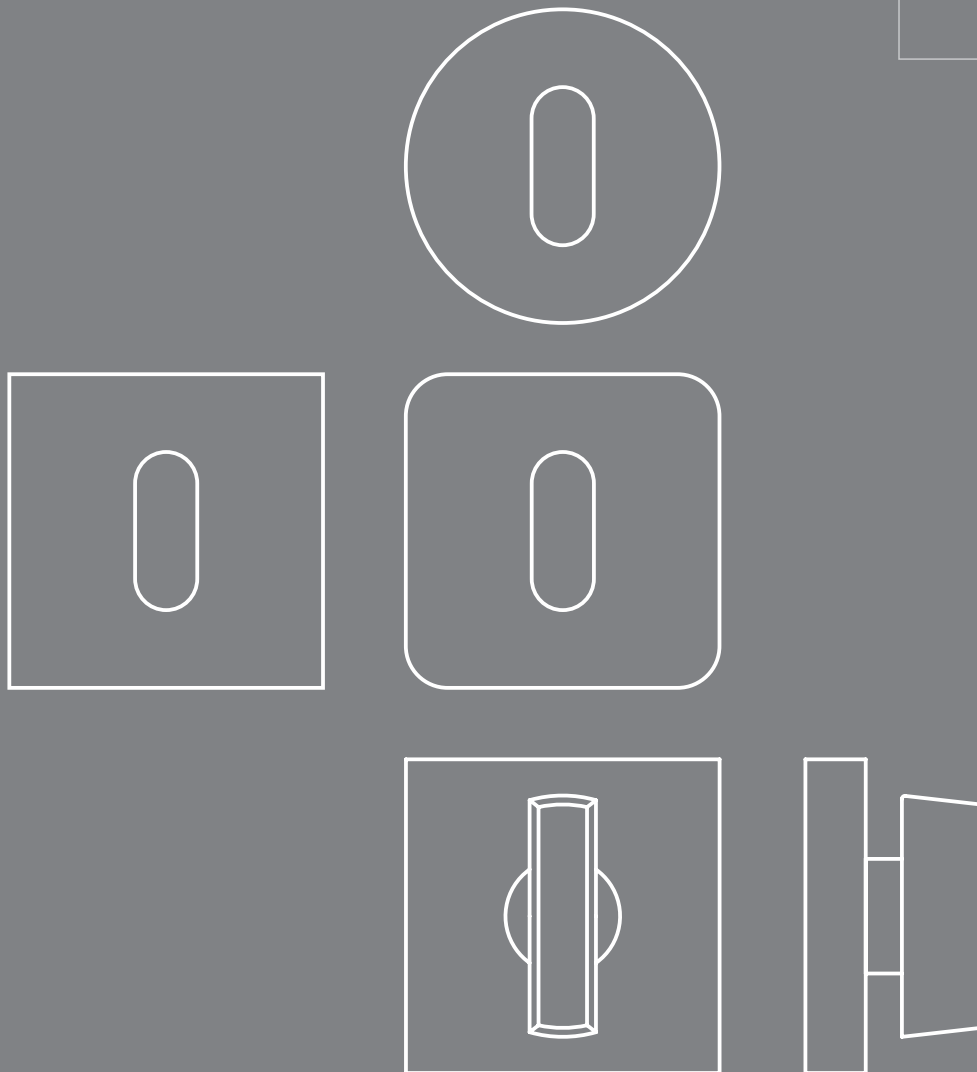

DI MANO IN MANO

# NOTTOLINI - TURNS & RELEASES



**NODN 01**

ottone massiccio - *solid brass*

**NODN 01**

nottolino dnd  
*dnd turn & release*



**RDN 01 + A**

ottone massiccio - *solid brass*



**RDN 01**

**RDN 01 + A**

set nottolino dnd su rosetta piana 45 mm  
con chiusura "A" con base in metallo  
*dnd turn & release "A" on flat rose 45 mm  
with metal base*

**RDN 01**

nottolino singolo dnd su rosetta piana 45 mm  
con base in metallo  
*dnd single turn snib on flat rose 45 mm  
with metal base*



**RDN 02 + A**

ottone massiccio - *solid brass*



**RDN 02**

**RDN 02 + A**

set nottolino dnd su rosetta bombata 45 mm  
con chiusura "A" con base in metallo  
*dnd turn & release "A" on rounded rose 45 mm  
with metal base*

**RDN 02**

nottolino singolo dnd su rosetta bombata 45 mm  
con base in metallo  
*dnd single turn snib on rounded rose 45 mm  
with metal base*



**RDN 03 + A**

ottone massiccio - *solid brass*



**RDN 03**

**RDN 03 + A**

set nottolino dnd su rosetta piana 52 mm  
con chiusura "A" con base in metallo  
*dnd turn & release "A" on flat rose 52 mm  
with metal base*

**RDN 03**

nottolino singolo dnd su rosetta piana 52 mm  
con base in metallo  
*dnd single turn snib on flat rose 52 mm  
with metal base*



**RDN05 + A**

ottone massiccio - *solid brass*



**RDN05**

**RDN 05 + A**

set nottolino dnd su rosetta quadra smussata 52 mm  
con chiusura "A" con base in metallo  
*dnd turn & release "A" on chamfered square rose 52 mm  
with metal base*

**RDN 05**

nottolino singolo dnd su rosetta quadra smussata 52 mm  
con base in metallo  
*dnd single turn snib on chamfered square rose 52 mm  
with metal base*

finiture / finishes

OLV - OS - OC - OCS - ONS - ORO - PVD - PVD INOX

# NOTTOLINI - TURNS & RELEASES



**NODN 10**

ottone massiccio - *solid brass*

**NODN 10**

nottolino dnd Logo  
*dnd Logo turn & release*



**RDN 10 + A**

ottone massiccio - *solid brass*



**RDN 10**

**RDN 10 + A**

set nottolino dnd Logo su rosetta piana 45 mm  
con chiusura "A" con base in metallo  
*dnd Logo turn & release "A" on flat rose 45 mm  
with metal base*

**RDN 10**

nottolino singolo dnd Logo su rosetta piana 45 mm  
con base in metallo  
*dnd Logo single turn snib on flat rose 45 mm  
with metal base*



**RDN 13 + A**

ottone massiccio - *solid brass*



**RDN 13**

**RDN 13 + A**

set nottolino dnd Logo su rosetta piana 52 mm  
con chiusura "A" con base in metallo  
*dnd Logo turn & release "A" on flat rose 52 mm  
with metal base*

**RDN 13**

nottolino singolo dnd Logo su rosetta piana 52 mm  
con base in metallo  
*dnd Logo single turn snib on flat rose 52 mm  
with metal base*



**RDN 15 + A**

ottone massiccio - *solid brass*



**RDN 15**

**RDN 15 + A**

set nottolino dnd Logo su rosetta quadra 52 mm  
con chiusura "A" con base in metallo  
*dnd Logo turn & release "A" on square rose 52 mm  
with metal base*

**RDN 15**

nottolino singolo dnd Logo su rosetta quadra 52 mm  
con base in metallo  
*dnd Logo single turn snib on square rose 52 mm  
with metal base*

finiture / finishes

OLV - OS - OC - OCS - ONS - ORO - PVD - PVD INOX

# ROSETTE-ROSES



**RD 01**  
OTTONE MASSICCIO - SOLID BRASS



**AROS#45NM80**

**RD 01**  
rosetta piana 45 mm  
flat rose 45 mm

**AROS#45NM80**  
base in metallo con molla D/S  
per rosette dnd 45 mm - mod. dep.  
metal base with R/L spring  
for dnd 45 mm roses - patented



**RD 02**  
OTTONE MASSICCIO - SOLID BRASS



**AROS#45NM80**

**RD 02**  
rosetta bombata 45 mm  
rounded rose 45 mm

**AROS#45NM80**  
base in metallo con molla D/S  
per rosette dnd 45 mm - mod. dep.  
metal base with R/L spring  
for dnd 45 mm roses - patented



**RD 03**  
OTTONE MASSICCIO - SOLID BRASS

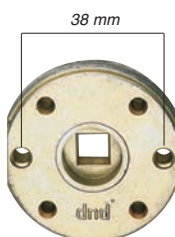

**AROS#52DM80**

**RD 03**  
rosetta piana 52 mm  
flat rose 52 mm

**AROS#52DM80**  
base in metallo con molla D/S  
per rosette dnd 52 mm - mod. dep.  
metal base with R/L spring  
for dnd 52 mm roses - patented

## FINITURE / FINISHES



OLV



OS



OC



OCS



ONS



ORO



PVD



PVD INOX



# ROSETTE-ROSES



**RD 04**

OTTONE MASSICCIO - SOLID BRASS

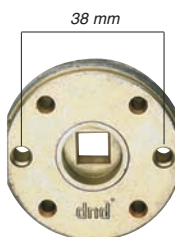

**AROS#52DM80**

**RD 04**

rosetta quadra 52 mm  
*square rose 52 mm*

**AROS#52DM80**

base in metallo con molla D/S  
per rosette dnd 52 mm - mod. dep.  
*metal base with R/L spring  
for dnd 52 mm roses - patented*



**RD 05**

OTTONE MASSICCIO - SOLID BRASS

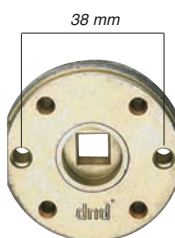

**AROS#52DM80**

**RD 05**

rosetta quadra smussata 52 mm  
*chamfered square rose 52 mm*

**AROS#52DM80**

base in metallo con molla D/S  
per rosette dnd 52 mm - mod. dep.  
*metal base with R/L spring  
for dnd 52 mm roses - patented*

# BOCCHETTE - ESCUTCHEONS



bocchetta piana 45 mm  
flat escutcheon 45 mm



**BD 01P - PATENT**  
ottone massiccio - solid brass

bocchetta piana 45 mm  
flat escutcheon 45 mm



**BD 01Y - YALE**  
ottone massiccio - solid brass

base nylon 45 mm per bocchette dnd BD 01 - BD 02  
nylon base 45 mm for dnd BD 01 - BD 02 escutcheons



**ABOC#DND2**

bocchetta bombata 45 mm  
rounded escutcheon 45 mm



**BD 02P - PATENT**  
ottone massiccio - solid brass

bocchetta bombata 45 mm  
rounded escutcheon 45 mm



**BD 02Y - YALE**  
ottone massiccio - solid brass

base nylon 45 mm per bocchette dnd BD 01 - BD 02  
nylon base 45 mm for dnd BD 01 - BD 02 escutcheons



**ABOC#DND2**

bocchetta piana 52 mm  
flat escutcheon 52 mm



**BD 03P - PATENT**  
ottone massiccio - solid brass

bocchetta piana 52 mm  
flat escutcheon 52 mm



**BD 03Y - YALE**  
ottone massiccio - solid brass







base nylon 52 mm per bocchette dnd BD 03  
nylon base 52 mm for dnd BD 03 escutcheons



**ABOC#520YASP1**



# BOCCHETTE - ESCUTCHEONS



<p>bocchetta quadra 52 mm square escutcheon 52 mm</p>  <p><b>BD 04P - PATENT</b> ottone massiccio - <i>solid brass</i></p>	<p>bocchetta quadra 52 mm square escutcheon 52 mm</p>  <p><b>BD 04Y - YALE</b> ottone massiccio - <i>solid brass</i></p>	<p>base nylon 50 mm per bocchette dnd BD 04 - BD 05 nylon base 50 mm for dnd BD 04 - BD 05 escutcheons</p>  <p><b>ABOC#507YARA9</b></p>
<p>bocchetta quadra smussata 52 mm chamfered square escutcheon 52 mm</p>  <p><b>BD 05P - PATENT</b> ottone massiccio - <i>solid brass</i></p>	<p>bocchetta quadra smussata 52 mm chamfered square escutcheon 52 mm</p>  <p><b>BD 05Y - YALE</b> ottone massiccio - <i>solid brass</i></p>	<p>base nylon 50 mm per bocchette dnd BD 04 - BD 05 nylon base 50 mm for dnd BD 04 - BD 05 escutcheons</p>  <p><b>ABOC#507YARA9</b></p>

# PLACCHE - PLATES

159

 <p><b>PL 169</b> placca Quadra <i>Quadra plate</i></p>	 <p><b>PL D01</b> placca dnd bombata <i>convex dnd plate</i></p>	<p>FINITURE / FINISHES OLV - OS - OC - OCS - ONS ORO - PVD - PVD INOX</p>
--	---	---

# PACKAGING



160



# PACKAGING



DI MANO IN MANO

# ESPOSITORI DISPLAYS



**ESP05**  
espositore dnd da banco mm 215 x 200 x 325 h  
*dnd desk display mm 215 x 200 x 325 h*

162



**ESP01**  
espositore dnd da parete mm 500 x 1.000 h  
*dnd wall display mm 500 x 1.000 h*



**possibilità di montaggio a più moduli**  
*possibility of placing more units side by side*

# ESPOSITORI DISPLAYS



**ESP02**  
espositore dnd da parete mm 500 x 2.000 h  
dnd wall display mm 500 x 2.000 h



**possibilità di montaggio a più moduli**  
*possibility of placing more units side by side*

# ESPOSITORI DISPLAYS



DI MANO IN MANO



## ESP06

espositore dnd fisso 3 lati mm 500 x 500 x 2.000 h  
*dnd 3 sides display mm 500 x 500 x 2.000 h*

# ESPOSITORI DISPLAYS



DI MANO IN MANO

## ESP10

espositore dnd mm 980 x 980 x 1.600 h  
dnd display mm 980 x 980 x 1.600 h

Design: Karim Rashid



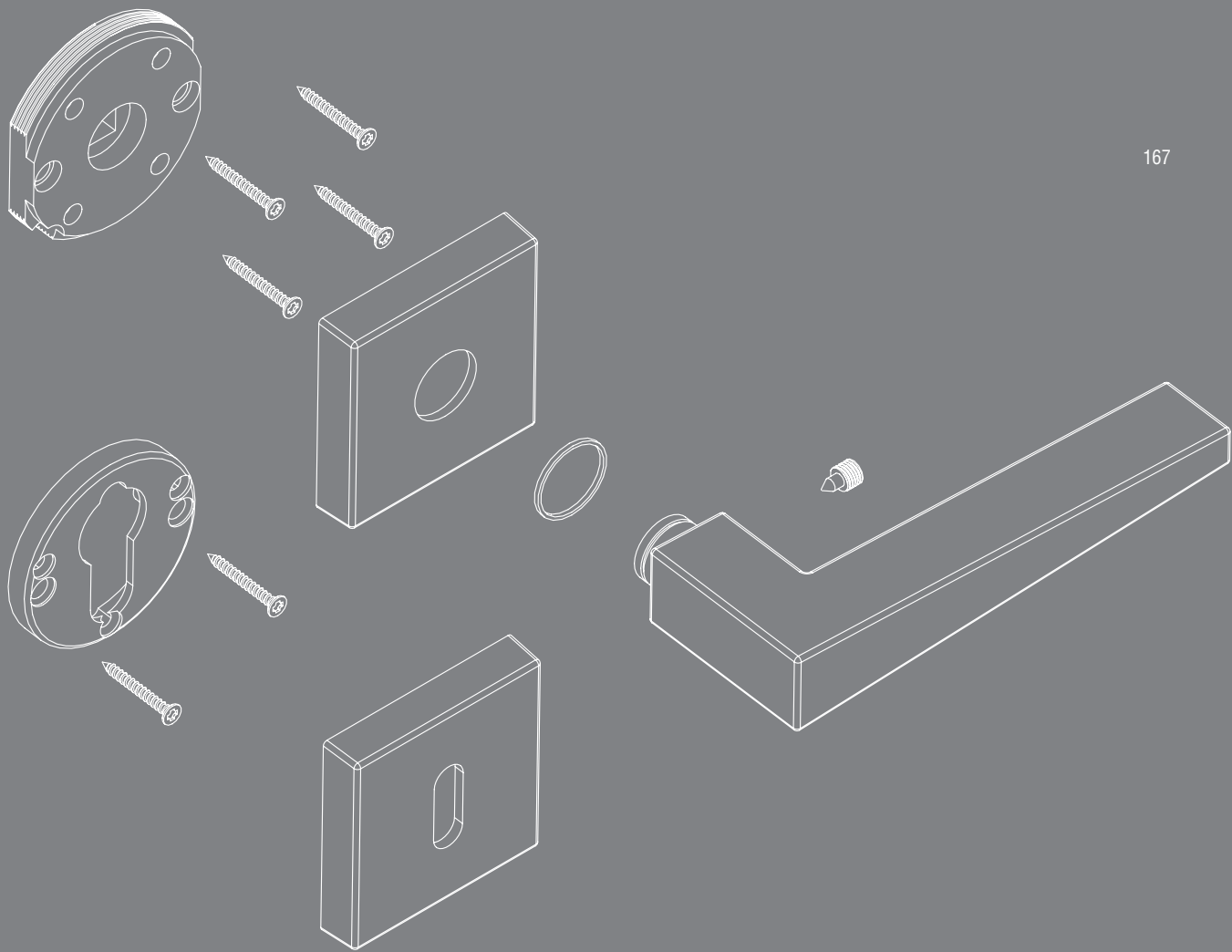

montaggio maniglie su placca dnd - door handles assembling on dnd plate

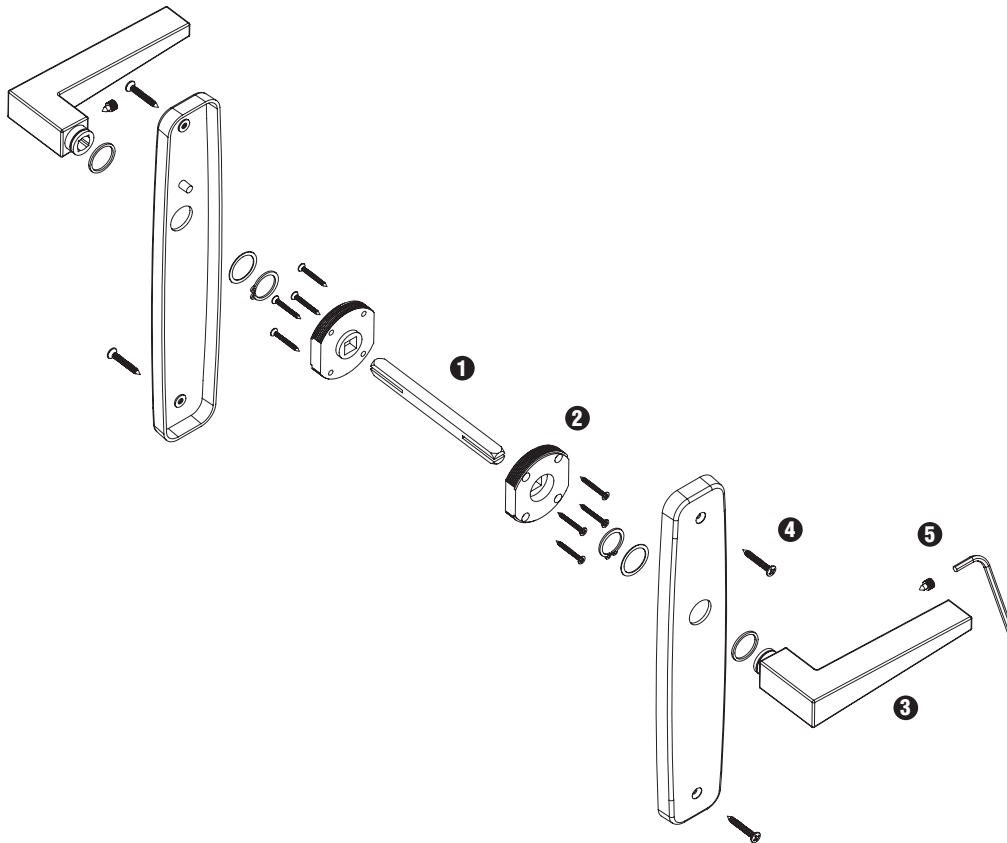

168

montaggio maniglie su placca quadra - door handles assembling on square plate

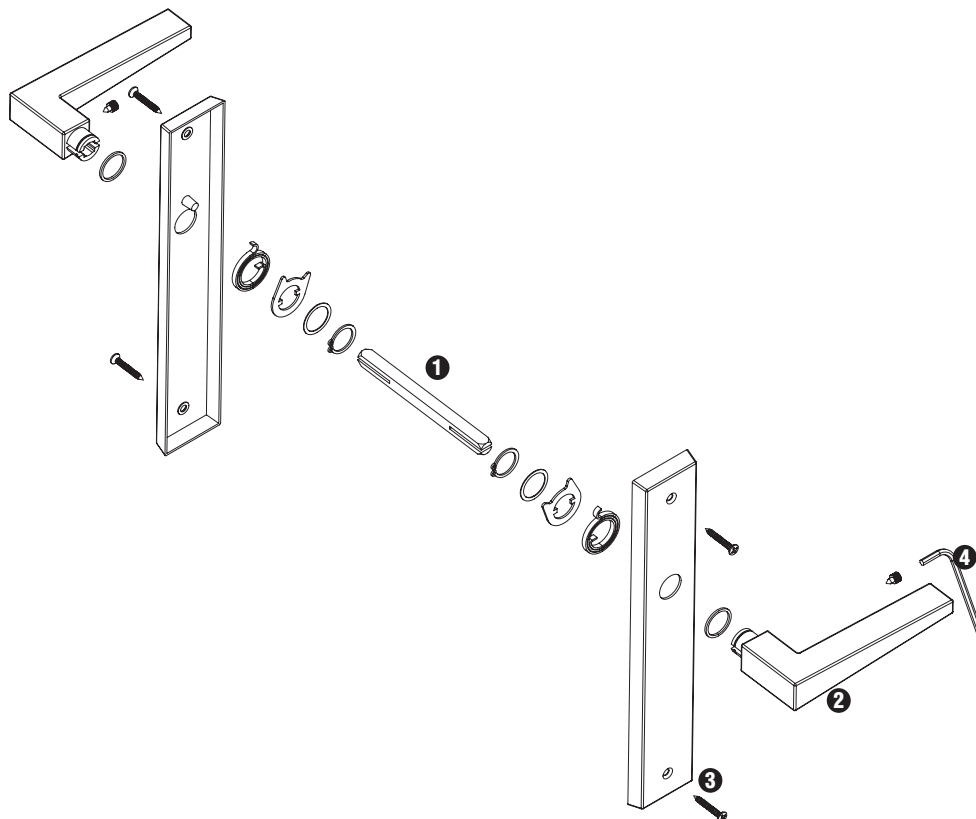

montaggio maniglie su rosetta e bocchetta 45 mm  
door handles assembling on rose and escutcheon 45 mm

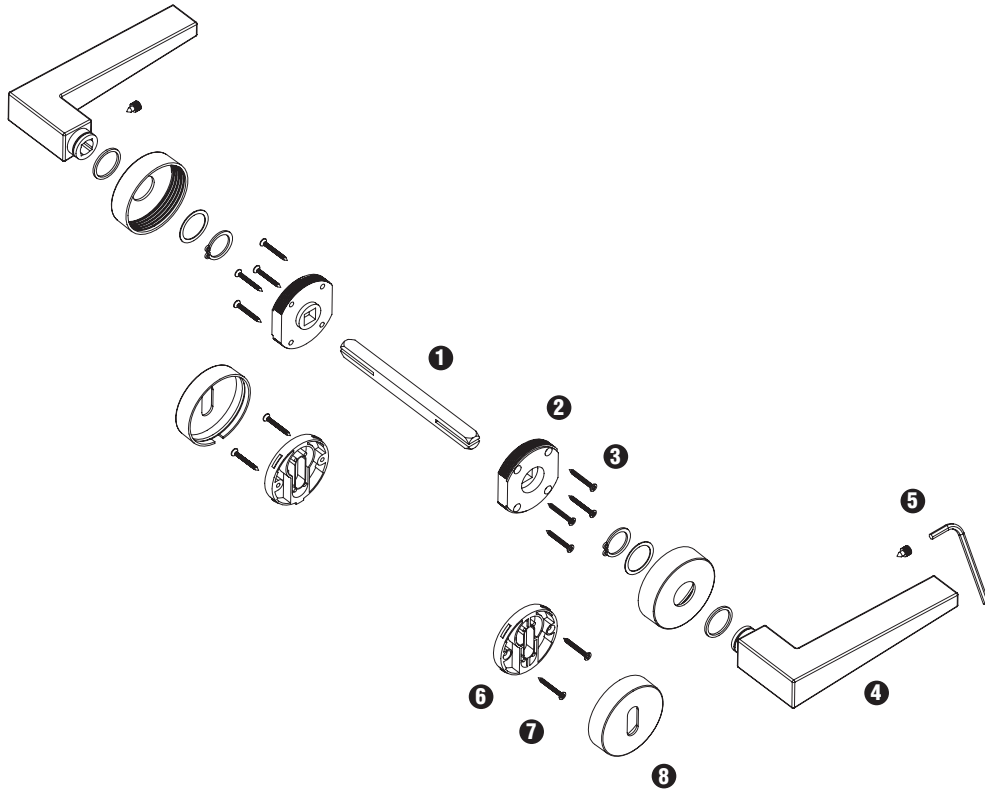

montaggio maniglie su rosetta e bocchetta 52 mm  
door handles assembling on rose and escutcheon 52 mm

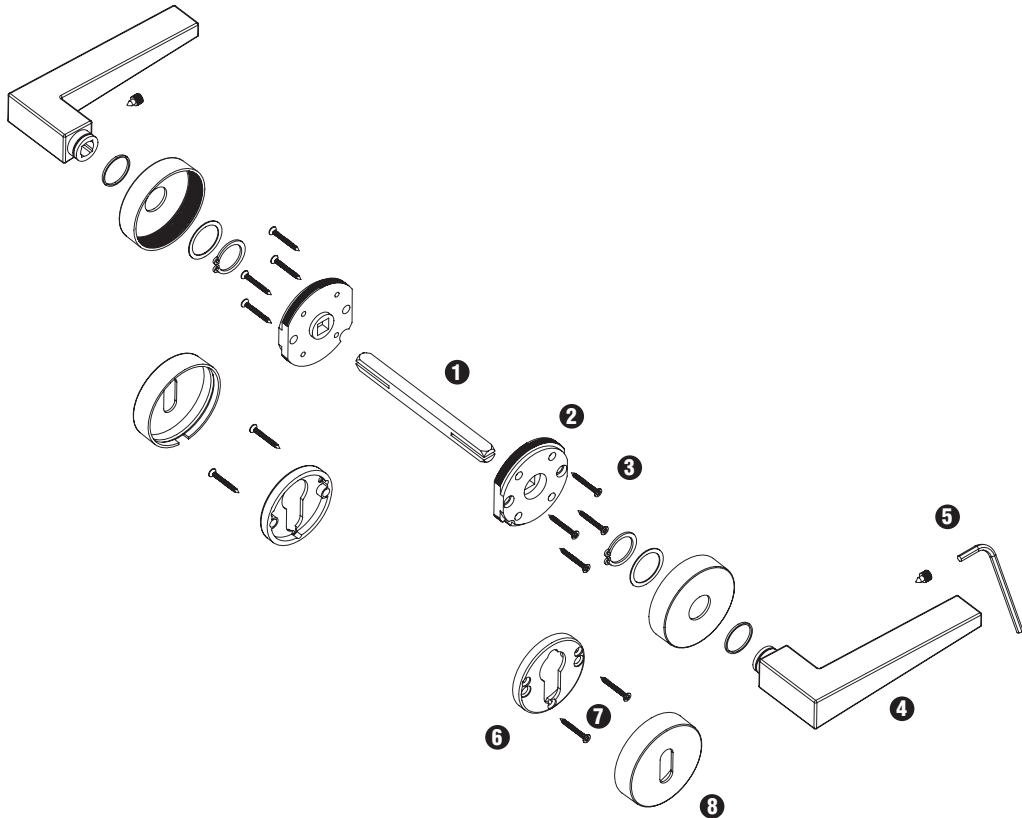

montaggio maniglie su rosetta e bocchetta 52 mm con bussole e viti di connessione  
door handles assembling on rose and escutcheon 52 mm with bushes and through fixings

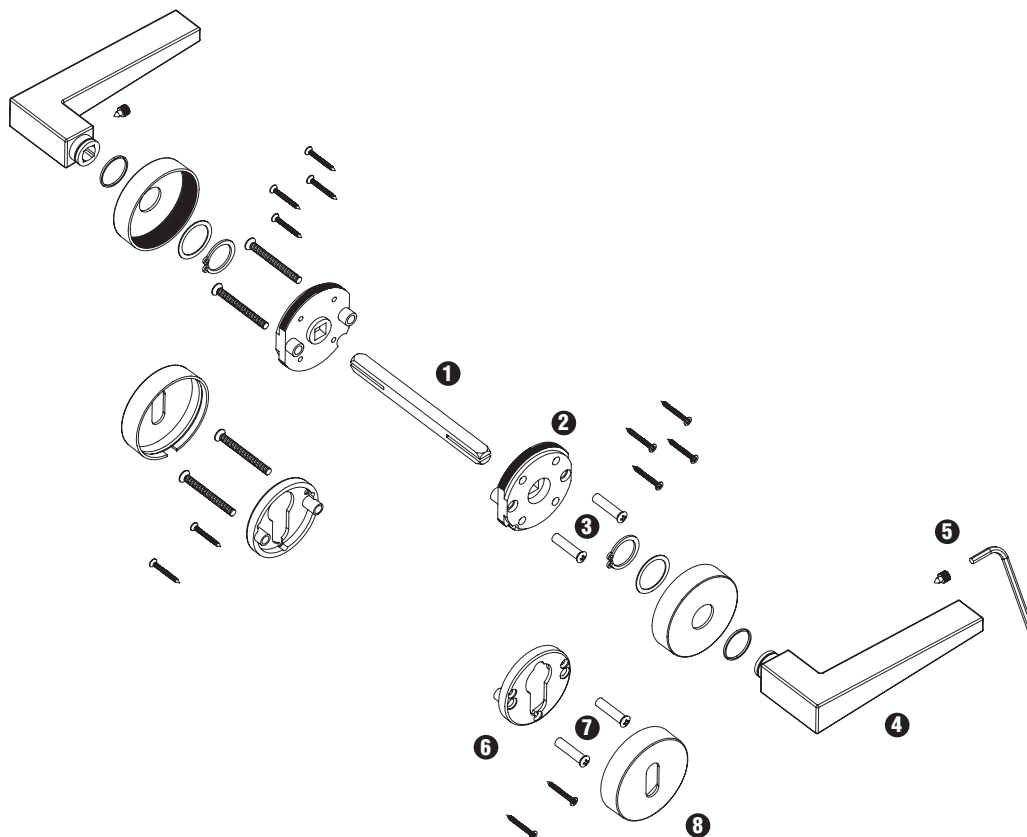

170

montaggio maniglie su rosetta e bocchetta quadra mm 52  
door handles assembling on square rose and escutcheon 52 mm

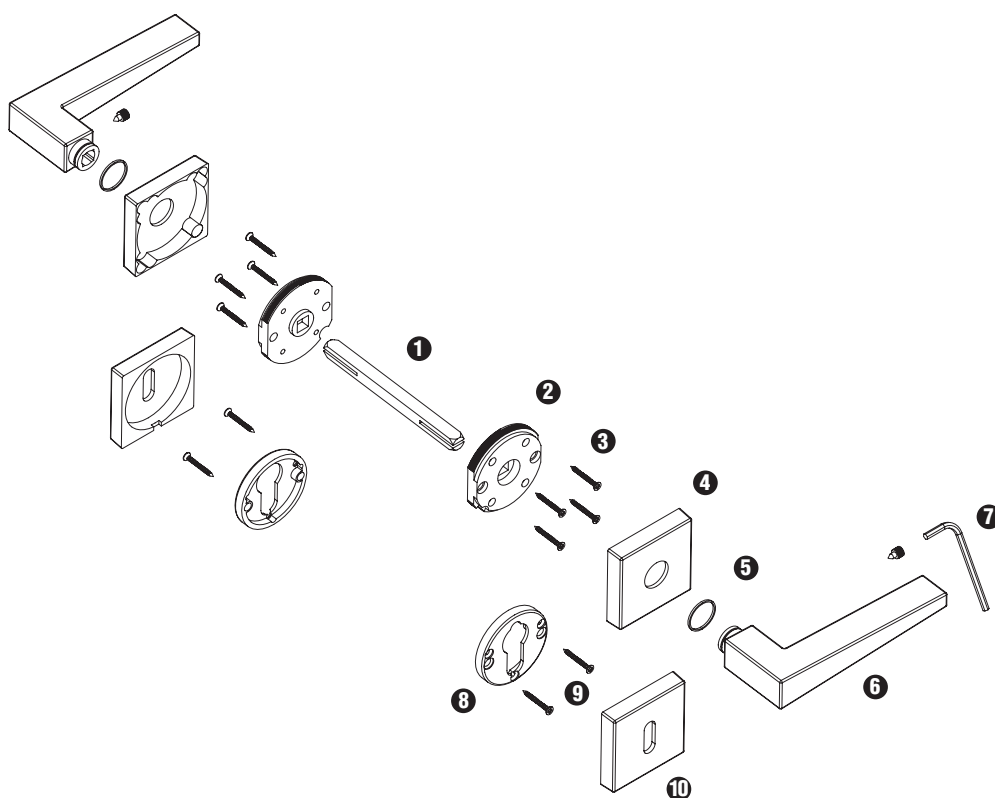

montaggio maniglie su rosetta e bocchetta quadra 52 mm con bussole e viti di connessione  
door handles assembling on square rose and escutcheon 52 mm with bushes and through fixings

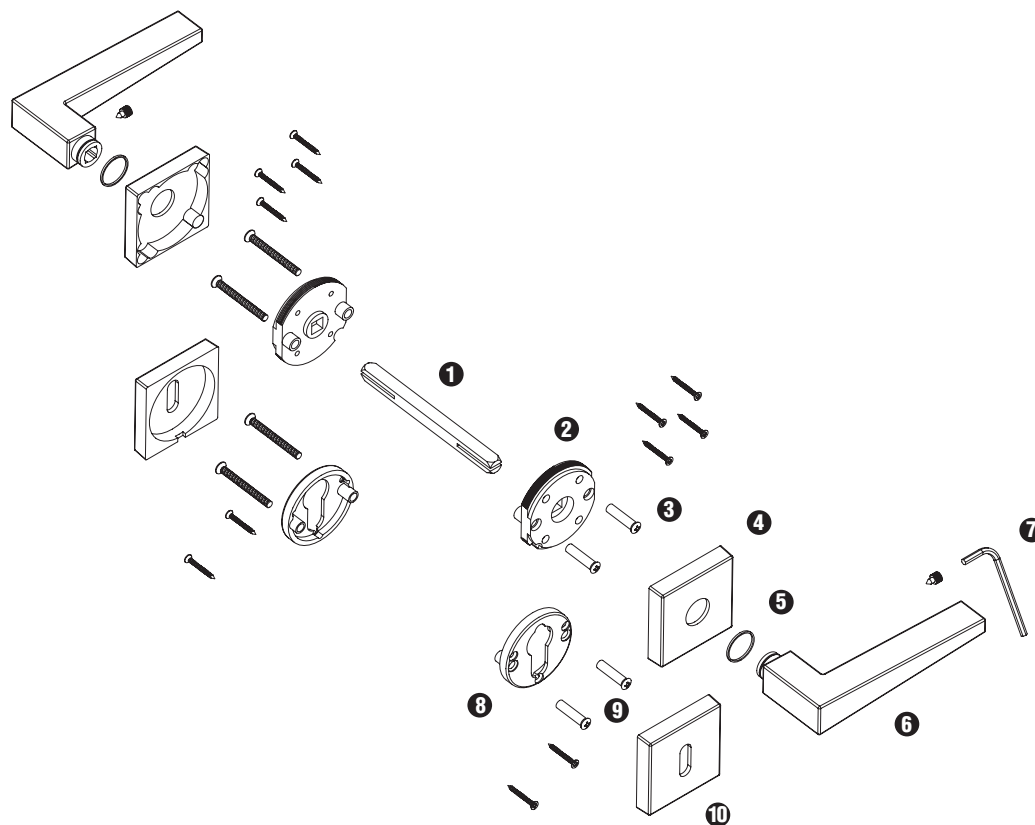

# SISTEMI DI FISSAGGIO ASSEMBLING SYSTEMS



172

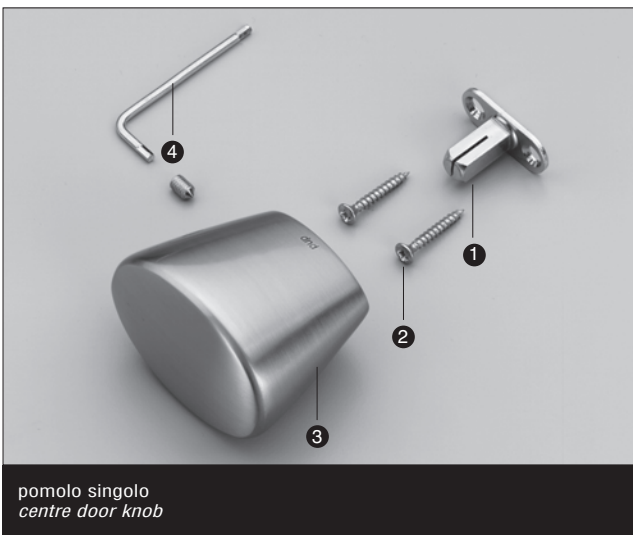

# SISTEMI DI FISSAGGIO ASSEMBLING SYSTEMS



# SISTEMI DI FISSAGGIO ASSEMBLING SYSTEMS

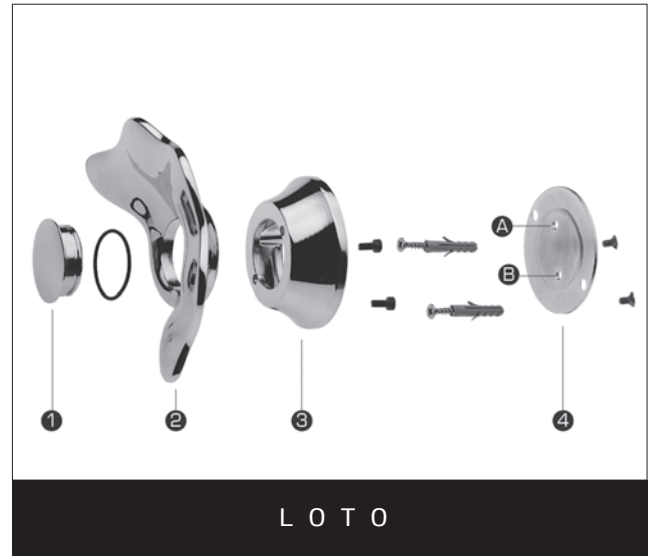

174

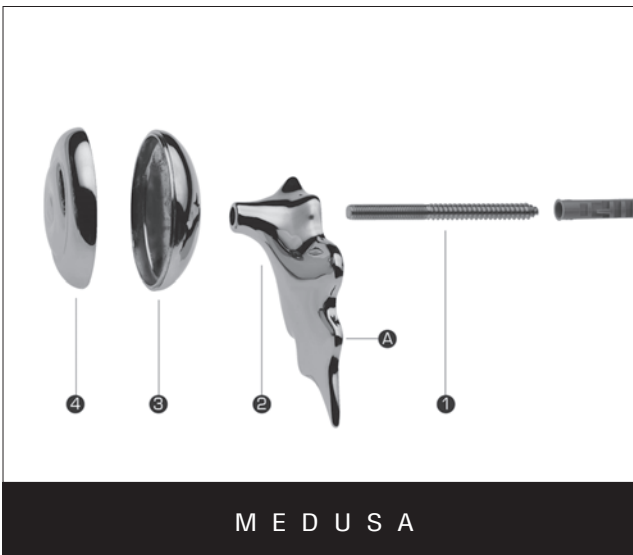





D I M A N O I N M A N O



**dnd** è un marchio di FMN Martinelli S.p.A.  
località Piani di Mura 2  
25070 Casto (BS) Italia  
Tel. +39-0365-899113 r.a. Fax +39-0365-899118

**[www.dndmaniglie.it](http://www.dndmaniglie.it)**

Rproduzione vietata, tutti i diritti riservati  
© 2008 - FMN Martinelli Spa

*Si ringrazia il personale ed i collaboratori per il costante  
impegno e partecipazione tesi al raggiungimento dei nuovi obiettivi.  
Un ringraziamento particolare a tutti i fornitori che professionalmente  
hanno permesso la realizzazione del presente catalogo*

*We thank our staff and collaborators for the continuous  
and great work leaned toward the archievement of the new goals.  
A special acknowledgement to all the suppliers who have enabled  
the realisation of this catalogue.*

*Concept and graphic design  
Mauro Ronchi*