

2010

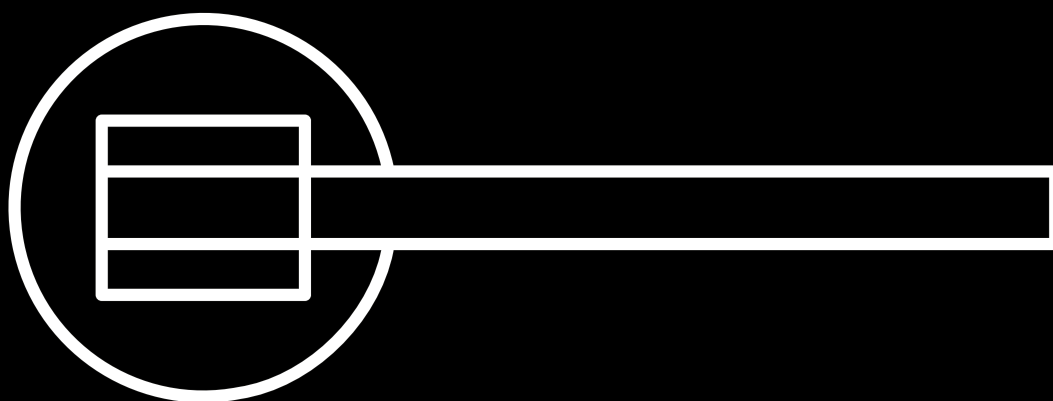

DI MANO IN MANO



www.dndmaniglie.it

I N D I C E - I N D E X

Maniglie - Door handles

CHANGE	3
CHANGE 02	6
CHANGE-B	9
KORPO	13
PEEK COLOR	17
PEEK	21
ESA	25
EDRA-B	29
EDRA-B 02	31

EDRA MANIGLIONI PER ALZANTE SCORREVOLE <i>PULL HANDLES FOR LIFT SLIDING SYSTEM</i>	33
FLUKE MANIGLIONE - <i>PULL HANDLE</i>	39
BATTENTI - <i>DOOR KNOCKERS</i>	43

Articoli vari - Door handles	47
FERMAPORTA - <i>DOOR STOP</i>	49
ACCESSORI PER SCORREVOLI - <i>SLIDIG DOOR HANDLES</i>	50
ROSETTE - <i>ROSES</i>	54
BOCCHETTE - <i>ESCUTCHEONS</i>	55
FINITURE - <i>FINISHES</i>	56
CONDIZIONI GENERALI DI VENDITA - <i>GENERAL SALE TERMS</i>	58





NOVITA' 2010

Con il 2010 dnd continua il suo percorso di ricerca su materia, forma e colore, celebrando l'inizio di una nuova promettente collaborazione. Lo Studio Sandro Santantonio design firma un progetto di grande qualità estetica che attesterà dnd come promotore del design più innovativo. Uno straordinario lavoro di sperimentazione che farà della nuova maniglia Change un oggetto del desiderio, capace di caratterizzare fortemente l'ambiente.

Sempre molto riconoscibile la presenza di Karim Rashid attraverso le sue maniglie Korpo e Peek: un inno alle forme fluide e sensuali che tanto piacciono all'artista. Con la versione colorata di Peek, il designer lancia un'iniezione di colore ed esuberanza che fanno della Peek color una maniglia di tendenza. Portano la firma di Mauro Ronchi le maniglie Esa ed Edra; dal design minimalista che contraddistingue lo stile del designer tra i fondatori del marchi DND.

dnd brand continues his run of search on subject form and color, starting a new and promising collaboration. Sandro Santantonio signs a project of great aesthetical quality that will recognize dnd as promoter of the most innovative design. An extraordinary work of experimentation that will make the new Change handle an object of the desire, able to strongly characterize every environment. Always very recognizable the presence of Karim Rashid through his Korpo and Peek handles, fluid and sensual shapes that he loves particularly. With the coloured version of Peek the designer proposes an injection of colour and exuberance making the Peek Color handle an object of fashion.

Edra and Esa handles are signed by Mauro Ronchi; a minimalist design that countersigns the style of the designer, among the founders of the dnd brand.





CHANGE

Design: Sandro Santantonio

Un cambiamento che si annuncia a partire dal nome.

CHANGE è una maniglia che ha nella trasformazione la sua ragione di essere. Mai uguale a se stessa e sempre disposta a cambiare pelle in una metamorfosi veloce e sorprendente. CHANGE esprime libertà, sperimentazione, edonismo. La maniglia studiata da Sandro Santantonio per dnd è concepita in modo innovativo: al momento dell'acquisto ognuno può comporla in base alla propria personalità e fantasia.

Desiderate in seguito cambiare la grafica? Il sottile parallelepipedo che forma l'impugnatura può essere facilmente levato e sostituito con un altro dalla grafica diversa. Ben 14 rivestimenti grafici oltre alle tradizionali finiture dell'ottone fanno di Change un oggetto estremamente originale e versatile adattabile ad ogni modello abitativo. Con CHANGE dnd presenta un oggetto di grande progettualità e sperimentazione.

CHANGE: la maniglia che cambia con te.

A change which is revealed starting from the name.

CHANGE is a door handle which raison d'être is the transformation. Never the same, always available to change its skin in a quick and surprising metamorphosis, CHANGE expresses freedom, experimentation, hedonism. The door handle designed by Sandro Santantonio for dnd is conceived and structured in an innovative way: while purchasing CHANGE everyone can combine it according to one's own personality and imagination. Do you wish to change the graphic later? The thin parallelepiped which forms the grip can be easily taken off and replaced by another one with a different finish.

The 14 graphic coverings in addition to the traditional finishes of brass material make CHANGE an extremely original and versatile object, suitable for any housing. With CHANGE Dnd presents an object of great planning character and experimentation.

CHANGE: the door handle which changes with you.

CHANGE

Design: Sandro Santantonio
modello depositato

ottone stampato a caldo
hot stamped brass



DI MANO IN MANO

CH16

maniglia su rosetta e bocchetta 52 mm
door handle on rose and escutcheon 52 mm
(l'inserto va acquistato separatamente)
(the insert must separately be purchased)

CH20

cremonese con meccanismo
window handle with mechanism
(l'inserto va acquistato separatamente)
(the insert must separately be purchased)

CH21

martellina con meccanismo e q.7x45 mm
window handle with mechanism
and 7x45 mm spindle
(l'inserto va acquistato separatamente)
(the insert must separately be purchased)

CH22

martellina DK
DK window handle
(l'inserto va acquistato separatamente)
(the insert must separately be purchased)

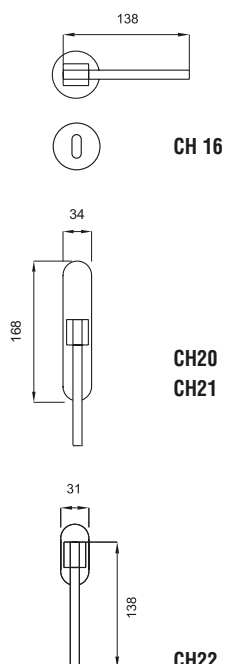

Finiture - finishes

OLV - OS - OC - OCS - ONS - OBN - ONO

INSERTO 3D IMAGE 3D IMAGE INSERT

- INS01** legno rigato / ruled wood
- INS02** righe colorate / colored lines
- INS03** righe bianco e nero / black and white lines
- INS04** quadro optical / chequered optical color
- INS05** quadro tessuto / chequered material color
- INS06** pied de poule / pied de poule color
- INS07** quadro bianco e nero / chequered black and white color
- INS08** foglia crema / leaf cream color
- INS09** foglia blu / leaf blue color
- INS10** fiore crema / flower cream color
- INS11** fiore rosa / flower pink color
- INS12** rosa rossa / red rose color
- INS13** foglia verde / leaf green color
- INS14** flusso blu / flow blue color

(l'inserto va acquistato separatamente)
(the insert must separately be purchased)



CHANGE

ottone stampato a caldo
hot stamped brass



Design: Sandro Santantonio

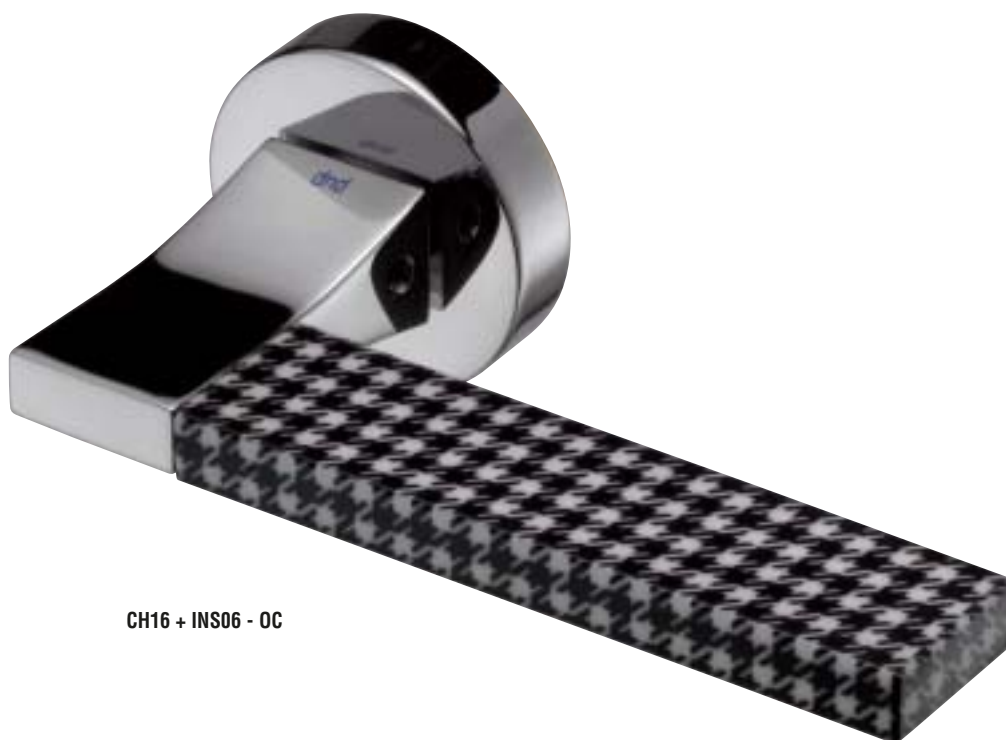

CH16 + INS06 - OC



DI MANO IN MANO

Sul nostro sito www.dndmaniglie.it
puoi provare tutte le combinazioni tra finiture e grafiche.
On our website www.dndmaniglie.it
you can try all the combinations among finishes and graphics.



INS08



INS09



INS10

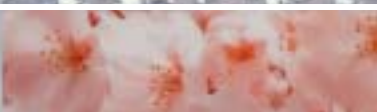

INS11



INS12



INS13



INS14

5 Simple gestures to change look at your CHANGE

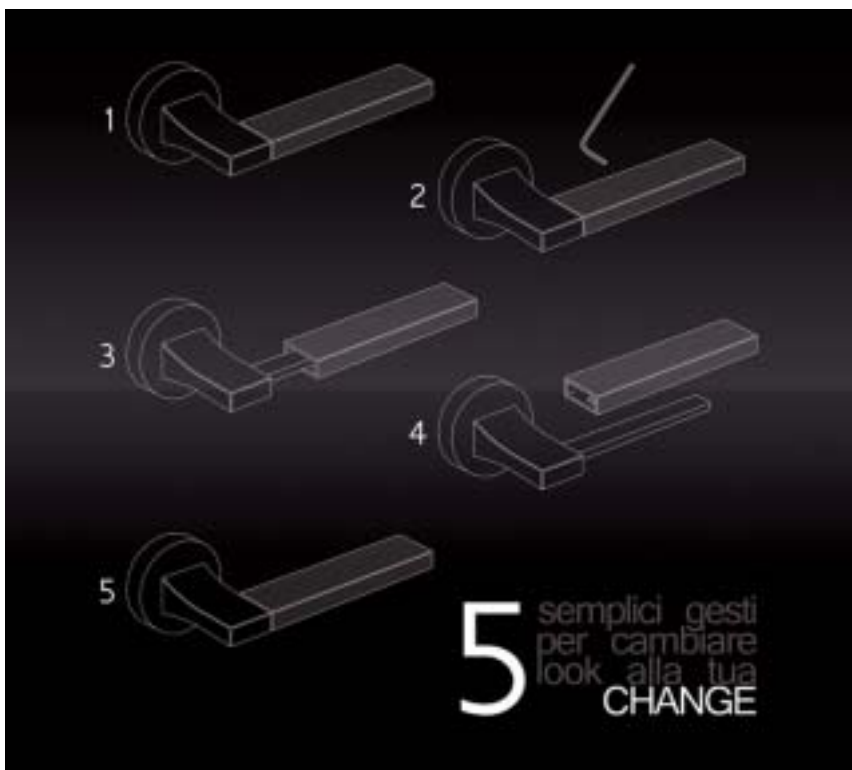

5 semplici gesti
per cambiare
look alla tua
CHANGE

CHANGE 02

Design: Sandro Santantonio

ottone stampato a caldo
hot stamped brass



DI MANO IN MANO

CH18

maniglia su rosetta e bocchetta quadra 52 mm
door handle on square rose and escutcheon 52 mm
(l'inserto va acquistato separatamente)
(the insert must separately be purchased)

CH23

cremonese con meccanismo
window handle with mechanism

CH24

martellina q.7 mm senza meccanismo
window handle 7 mm square without mechanism
(l'inserto va acquistato separatamente)
(the insert must separately be purchased)

CH25

martellina DK
DK window handle
(l'inserto va acquistato separatamente)
(the insert must separately be purchased)

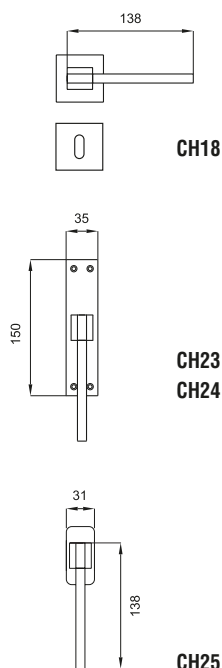

Finiture - finishes

OLV - OS - OC - OCS - ONS - OBN - ONO

INSERTO 3D IMAGE 3D IMAGE INSERT

- INS01 legno rigato / ruled wood
- INS02 righe colorate / colored lines
- INS03 righe bianco e nero / black and white lines
- INS04 quadro optical / chequered optical color
- INS05 quadro tessuto / chequered material color
- INS06 pied de poule / pied de poule color
- INS07 quadro bianco e nero / chequered black and white color
- INS08 foglia crema / leaf cream color
- INS09 foglia blu / leaf blue color
- INS10 fiore crema / flower cream color
- INS11 fiore rosa / flower pink color
- INS12 rosa rossa / red rose color
- INS13 foglia verde / leaf green color
- INS14 flusso blu / flow blue color

(l'inserto va acquistato separatamente)
(the insert must separately be purchased)



CHANGE 02

ottone stampato a caldo
hot stamped brass



Design: Sandro Santantonio

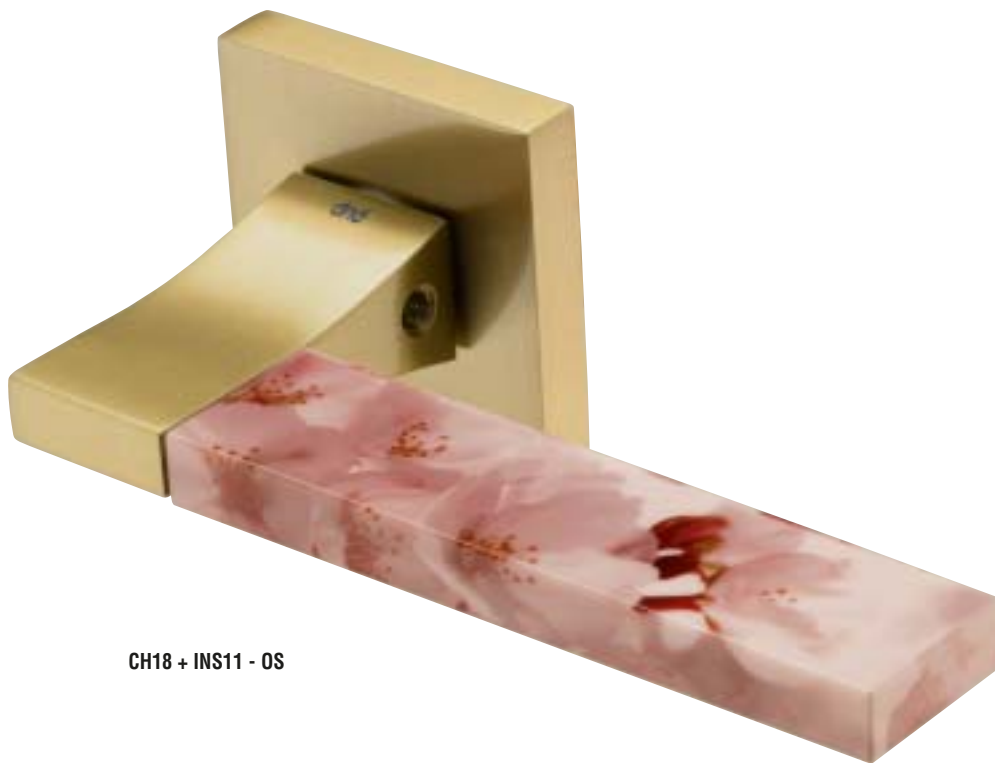

CH18 + INS11 - OS



DI MANO IN MANO

Sul nostro sito www.dndmaniglie.it
puoi provare tutte le combinazioni tra finiture e grafiche.
*On our website www.dndmaniglie.it
you can try all the combinations among finishes and graphics.*



INS08



INS09



INS10



INS11



INS12



INS13



INS14



ESP 11
Espositore da banco
Desk display





CHANGE-B

Design: Sandro Santantonio



CHANGE è proposta anche nella versione più tradizionale. Realizzata tutta in ottone, mantiene sempre la sua rigorosa forma originale. Disponibile nelle finiture abbinate in ottone lucido e satinato, in ottone cromo lucido e cromo satinato.

CHANGE is proposed in the most traditional version also. Brass realized, it maintains its rigorous original form. Available in the combined finishes polished-satin brass and polished-satin chrome

CHANGE-B

ottone stampato a caldo
hot stamped brass



Design: Sandro Santantonio



DI MANO IN MANO

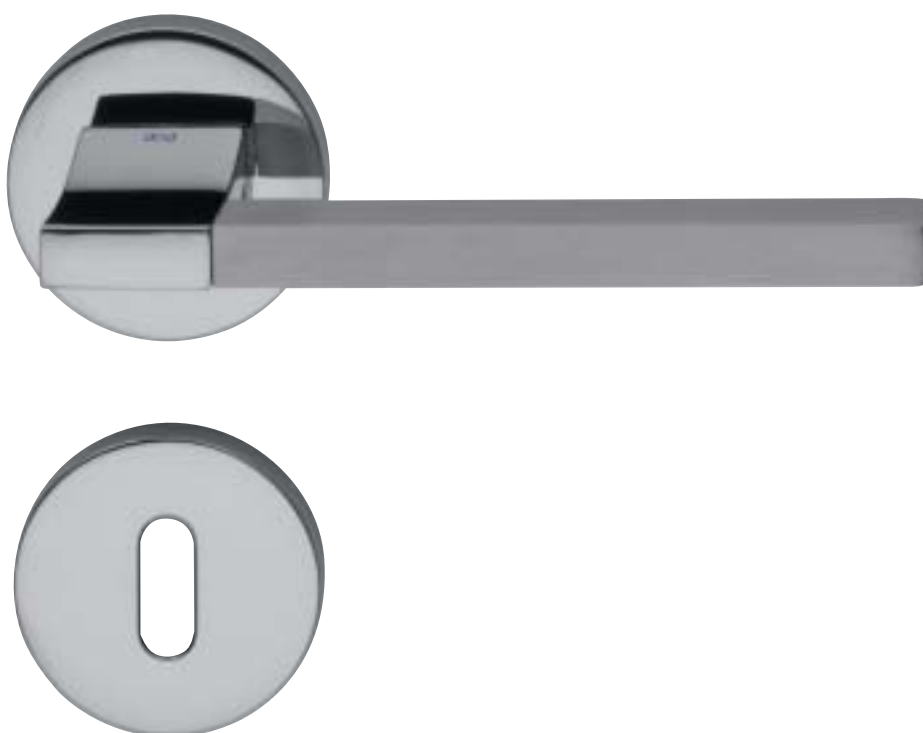

CB16 - CCS

Finiture - finishes
OLS - CCS

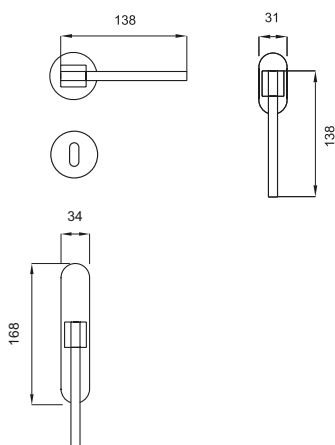

CB16
maniglia (con inserto in metallo)
su rosetta e bocchetta 52 mm
door handle (with metal insert)
on rose and escutcheon 52 mm

CB20
cremonese (con inserto in metallo)
con meccanismo
window handle (with metal insert)
with mechanism

CB21
martellina (con inserto in metallo)
con meccanismo e q.7x45 mm
window handle (with metal insert)
with mechanism and 7x45 mm spindle

CB22
martellina DK
DK window handle

FINITURE / FINISHES

OLS

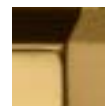

CCS

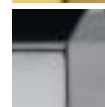

CHANGE-B 02

ottone stampato a caldo
hot stamped brass



Design: Sandro Santantonio

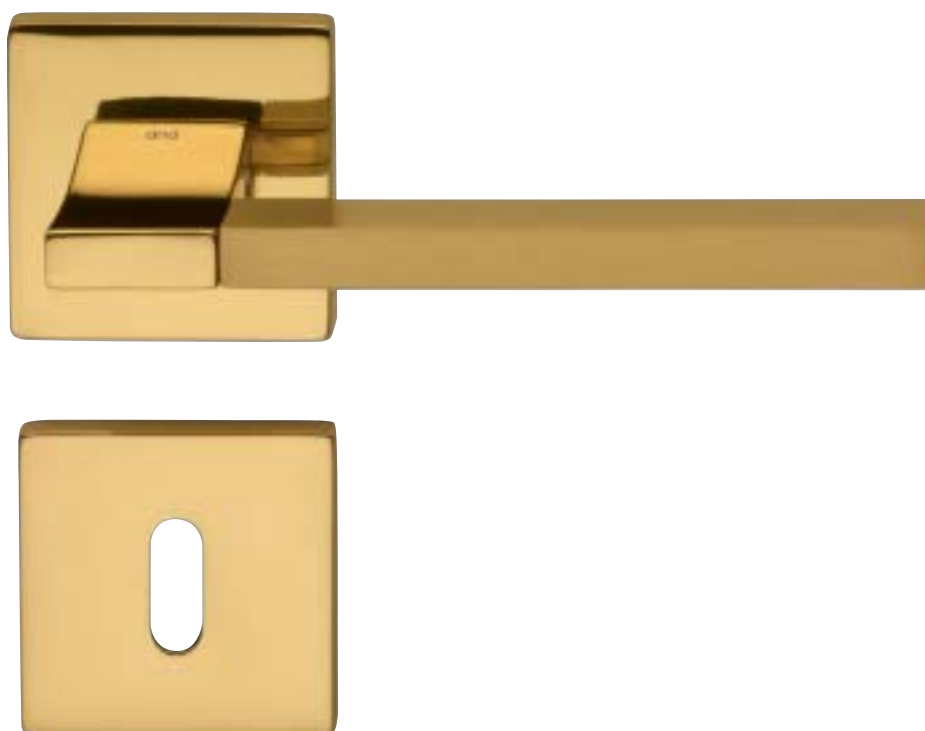

CB18 - OLS

Finiture - finishes
OLS - CCS



DI MANO IN MANO

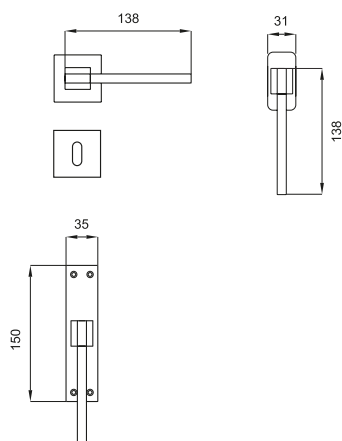

CB18

maniglia (con inserto in metallo)
su rosetta e bocchetta quadra 52 mm
door handle (with metal insert)
on square rose and escutcheon 52 mm

CB23

cremonese con meccanismo
window handle with mechanism

CB24

martellina q.7 mm senza meccansimo
window handle 7 mm square without mechanism

CB25

martellina DK quadro
square DK window handle

FINITURE / FINISHES

OLS

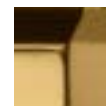

CCS

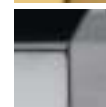



KORPO

Design: Karim Rashid



Una linea senza soluzione di continuità, quasi in movimento perpetuo, definisce una sagoma biomorfa che prende il nome di KORPO. La maniglia esprime ancora una volta la nota predilezione dell'artista per un design organico, fluido, voluttuoso che evoca il profilo morbido del corpo femminile.

A continuous line evoking a sense of moto perpetuo defines a biomorphic shape entitled KORPO. The handle once again expresses the known predilection of this artist for a kind of design organic, fluid and voluptuous that recalls the soft profile of female body

KORPO

ottone stampato a caldo
hot stamped brass



Design: Karim Rashid



DI MANO IN MANO



K016 - OC

Finiture - finishes

OLV - OS - OC - OCS - ONS - PVD - PVD INOX

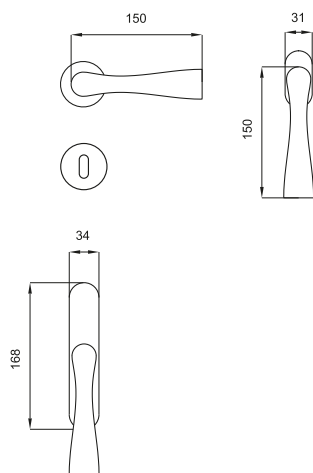

K016
maniglia su rosetta e bocchetta 52 mm
door handle on rose and escutcheon 52 mm

K020
cremonese con meccanismo
window handle with mechanism

K021
martellina con meccanismo e q. 7x45 mm
window handle with mechanism and 7x45 mm spindle

K022
martellina DK
DK window handle

FINITURE / FINISHES

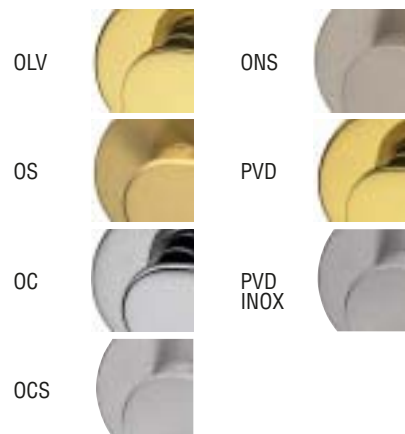

KORPO

ottone stampato a caldo
hot stamped brass



Design: Karim Rashid



DI MANO IN MANO

K016 - OCS

Finiture - finishes

OLV - OS - OC - OCS - ONS - PVD - PVD INOX

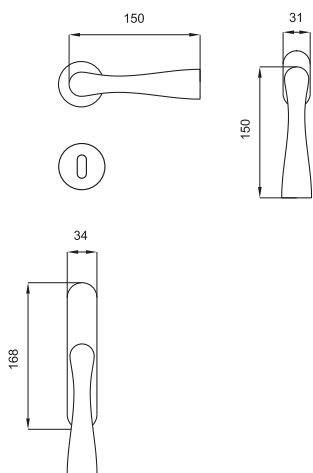

K016
maniglia su rosetta e bocchetta 52 mm
door handle on rose and escutcheon
52 mm

K020
cremonese con meccanismo
window handle with mechanism

K021
martellina con meccanismo e q. 7x45 mm
window handle with mechanism
and 7x45 mm spindle

K022
martellina DK
DK window handle

FINITURE / FINISHES

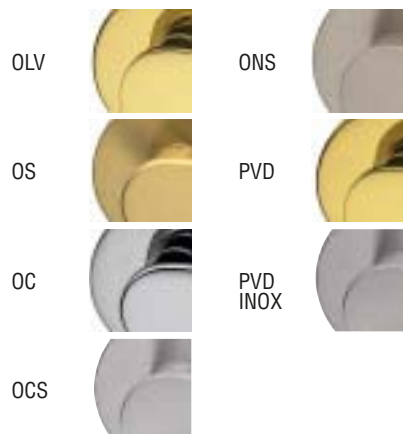



PEEK COLOR

Design: Karim Rashid



Il marchio dnd si affida ancora una volta all'estro di Karim Rashid per un nuovo progetto dalla carica giovanile, in grado di fare tendenza e soddisfare le esigenze dell'abitare contemporaneo. Nasce, così, PEEK COLOR, una maniglia dal profilo leggero, caratterizzata da linee rette ammorbidite da angoli arrotondati. Una forma focalizzata all'essenziale ma interrotta da un'iniezione di colore e vitalità che fa capolino dall'occhiello dell'impugnatura. L'interesse estetico della maniglia si concentra sulla pellicola adesiva che diventa un elemento di contrasto con la lucentezza delle parti metalliche. Grazie ad un mix di ricerca e avanguardia, la nuova maniglia di dnd si fa interprete di uno stile spumeggiante che trova nell'energia dei colori la sua ragione d'essere. PEEK COLOR abbina alle varie finiture (ottone lucido verniciato, ottone satinato, ottone cromo lucido, ottone cromo satinato, ottone nickel satinato e PVD) le nuance arancio, verde, blu e nero. Oltre alle quattro soluzioni cromatiche, dnd propone anche una pellicola luminescente che permette di individuare la maniglia anche al buio.

Dnd brand places his trust once again in Karim Rashid's inspiration to realize a new cool project to be able to become fashionable and satisfy modern living's requirements. That's why we present PEEK COLOR, a new handle with light profile, straight lines softened by rounded edges. The essential shape is interrupted by an injection of colour and vitality which peeps out from the eyelet. The aesthetics novelty is concentrated on the adhesive film in contrast with shining metal parts. Thanks to a combination of research and innovation, this new dnd handle embodies a sparkling style that finds its raison d'être in the energy of colours. PEEK COLOR combines different finishes (polished brass, satin brass, polished chrome, satin chrome and PVD) with the nuances of orange, green, blue and black colours. Besides, dnd proposes a phosphorescent film that allows to see the handle in the dark.

PEEK COLOR

ottone stampato a caldo
hot stamped brass



Design: Karim Rashid



DI MANO IN MANO



PC16 + 1 - OC

Finiture - finishes

OLV - OS - OC - OCS - ONS - PVD - PVD INOX

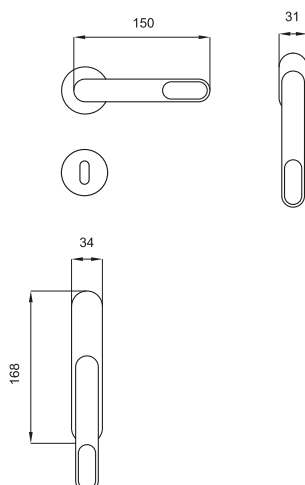

PC16-P plus

maniglia su rosetta e bocchetta 52 mm
door handle on rose and escutcheon 52 mm

PC20-P plus

cremonese con meccanismo
window handle with mechanism

PC21-P plus

martellina con meccanismo q.7x45 mm
window handle with mechanism
and 7x45 mm spindle

PC22-P plus

martellina DK
DK window handle

**plus = con 5 adesivi diversamente colorati
with 5 different colored stickers**

ADESIVI / STICKERS



1 arancio - orange

2 blu - blue

3 nero - black

4 verde - green

5 luminescente - luminescent

PEEK COLOR

ottone stampato a caldo
hot stamped brass



Design: Karim Rashid



DI MANO IN MANO

Finiture - finishes

OLV - OS - OC - OCS - ONS - PVD - PVD INOX

PC16-S single

maniglia su rosetta e bocchetta 52 mm
door handle on rose and escutcheon 52 mm

PC20-S single

cremonese con meccanismo
window handle with mechanism

PC21-S single

martellina con meccanismo q.7x45 mm
window handle with mechanism
and 7x45 mm spindle

PC22-S single

martellina DK
DK window handle

single = con 1 adesivo colorato a scelta
with 1 colored sticker to choice

FINITURE / FINISHES

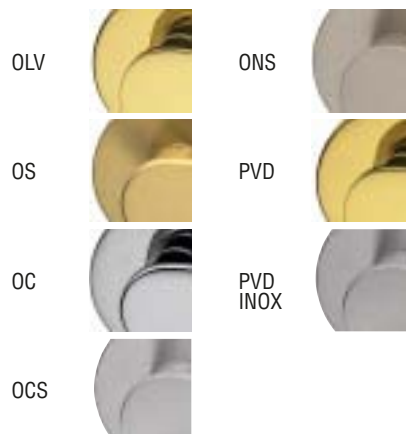



PEEK

Design: Karim Rashid



PEEK è un corpo unico definito da linee rette ammorbidite da angoli smussati. Una forma focalizzata verso l'essenziale interrotta da un particolare tocco di trasgressività: un curioso occhiello che riprende il medesimo profilo della maniglia e diventa il punto di attenzione e di eccentricità dell'intera impugnatura.

PEEK is a handle only defined by straight lines softened by rounded edges. An essential form interrupted by a particular transgressive touch: a curious buttonhole (peek) that takes back the same profile of the handle and becomes motive for attention and eccentricity of the same handle.

PEEK

ottone stampato a caldo
hot stamped brass



Design: Karim Rashid



DI MANO IN MANO



PK16 - OC

Finiture - finishes

OLV - OS - OC - OCS - ONS - PVD - PVD INOX

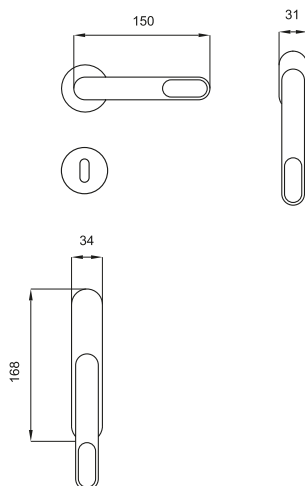

PK16
maniglia su rosetta e bocchetta 52 mm
door handle on rose and escutcheon 52 mm

PK20
cremonese con meccanismo
window handle with mechanism

PK21
martellina con meccanismo e q. 7x45 mm
window handle with mechanism and 7x45 mm spindle

PK22
martellina DK
DK window handle

FINITURE / FINISHES

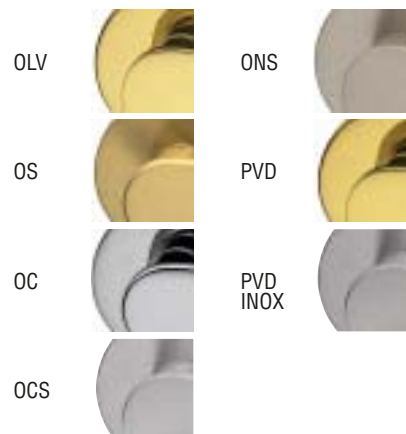

PEEK

ottone stampato a caldo
hot stamped brass



Design: Karim Rashid



DI MANO IN MANO

PK16 - OLV

Finiture - finishes

OLV - OS - OC - OCS - ONS - PVD - PVD INOX

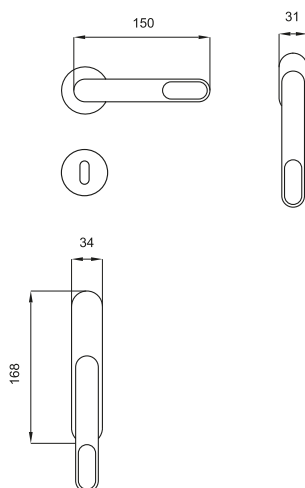

PK16
maniglia su rosetta e bocchetta 52 mm
door handle on rose and escutcheon 52 mm

PK20
cremonese con meccanismo
window handle with mechanism

PK21
martellina con meccanismo e q. 7x45 mm
window handle with mechanism and 7x45 mm spindle

PK22
martellina DK
DK window handle

FINITURE / FINISHES

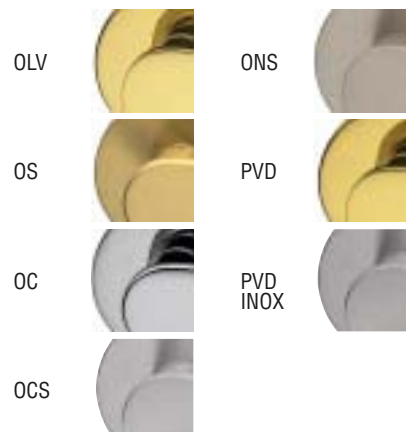





ESA

Design: Mauro Ronchi



Due semplici geometrie s'incontrano per dare corpo a una maniglia audace, dominata da linee rette e spigoli vivi. Il collo lucido si accosta all'impugnatura particolarmente leggera e maneggevole, capace di fare tendenza nelle versioni cromo satinato e nel colore bianco e nero. Mauro Ronchi firma la maniglia Esa dalla forma minimalista, adatta ad ambienti moderni e tecnologici.

The meeting of two simple geometric parts give substance to an audacious handle, dominated by straight lines and alive edges. The shiny neck approaches to the particularly light and manageable hilt with pretension to make tendency with its polished chrome version and coloured one, white and black. ESA handle, characterized by a minimalist shape, suitable for modern and technological environments, is signed by Mauro Ronchi.

ESA

alluminio e zama
aluminium and zamac



Design: Mauro Ronchi



DI MANO IN MANO



ES19 - CBI



ES19 - CCS

Finiture - finishes
CNE - CBI - CCS

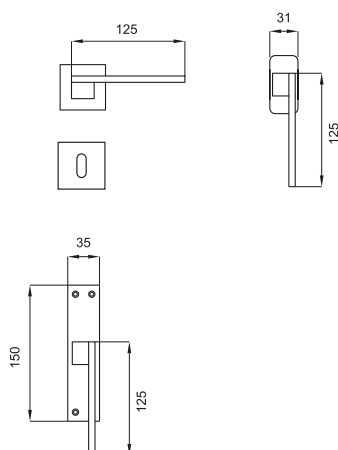

ES19
maniglia su rosetta R034 e bocchetta B041
quadra 50 mm base nylon
*door handle on square rose
and escutcheon 50 mm nylon base*

ES23
cremonese con meccanismo
window handle with mechanism

ES24
martellina q.7 senza meccanismo
*window handle 7 mm square
without mechanism*

ES25
martellina DK quadro
square DK window handle

FINITURE / FINISHES

CNE



CBI



CCS

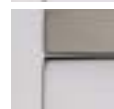

ESA

alluminio e zama
aluminium and zamac



Design: Mauro Ronchi



ES19 - CNE

Finiture - finishes
CNE - CBI - CCS



DI MANO IN MANO

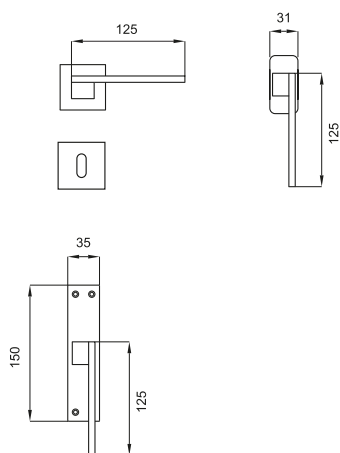

ES19
maniglia su rosetta R034 e bocchetta B041
quadra 50 mm base nylon
door handle on square rose
and escutcheon 50 mm nylon base

ES23
cremonese con meccanismo
window handle with mechanism

ES24
martellina q.7 senza meccanismo
window handle 7 mm square
without mechanism

ES25
martellina DK quadro
square DK window handle

FINITURE / FINISHES

CNE



CBI

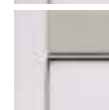

CCS

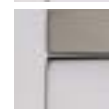





EDRA-B

Design: Mauro Ronchi

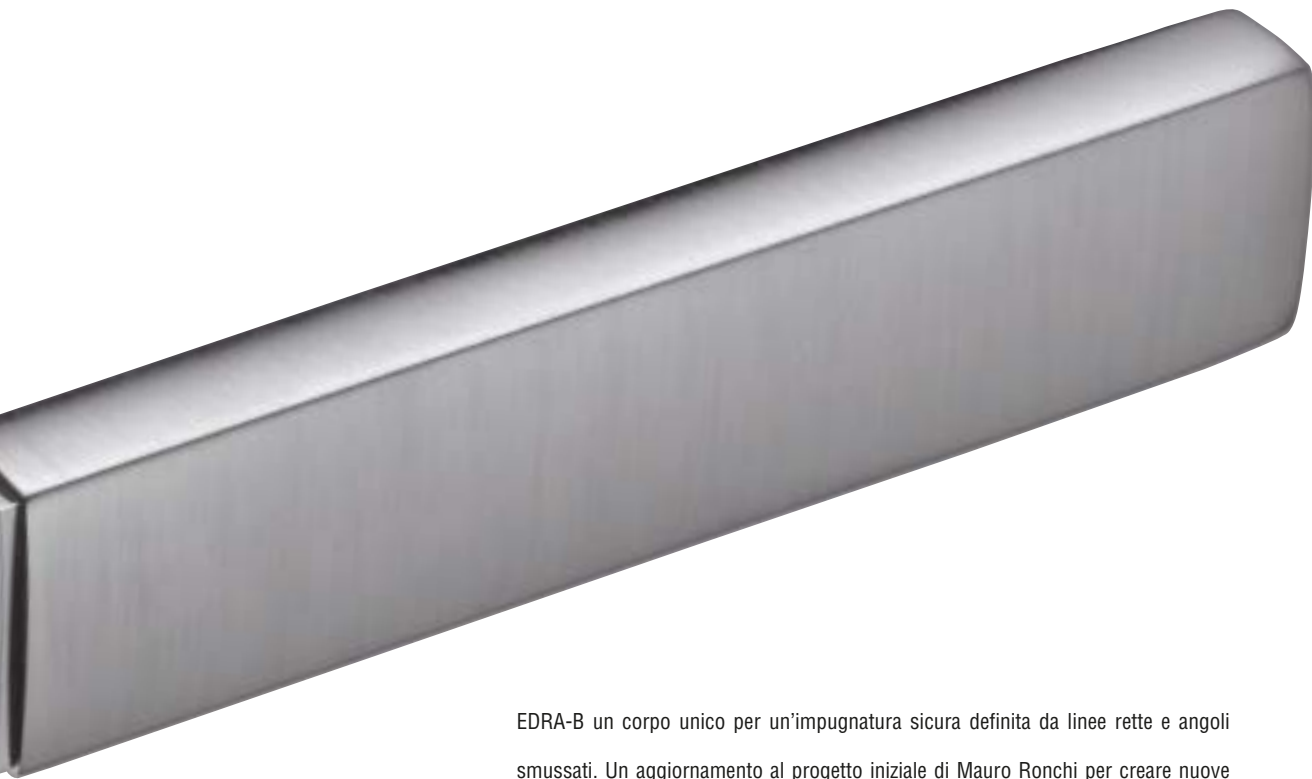

EDRA-B un corpo unico per un'impugnatura sicura definita da linee rette e angoli smussati. Un aggiornamento al progetto iniziale di Mauro Ronchi per creare nuove finiture e varianti sempre più richieste dal mercato. Linearità, pulizia e rigore sono le principali caratteristiche di questa maniglia. Disponibile nelle finiture accoppiate cromato e cromo satinato.

A handle defined by straight lines and rounded edges. The initial project of Mauro Ronchi has been updated in order to offer new finishes and variations more and more required by the market. Linearity and simplicity are the characteristics of this handle. Available in the combined finishes polished and satin chrome brass.

EDRA-B

ottone stampato a caldo
hot stamped brass



Design: Mauro Ronchi



DI MANO IN MANO



EB15 - CCS

Finiture - finishes
OLS - CCS

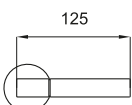
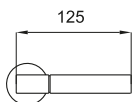

EB15
maniglia su rosetta e bocchetta 45 mm
door handle on rose and escutcheon
45 mm

EB16
maniglia su rosetta e bocchetta 52 mm
door handle on rose and escutcheon
52 mm

FINITURE / FINISHES

OLS



CCS



EEDRA-B 02

ottone stampato a caldo
hot stamped brass



Design: Mauro Ronchi



EB19 - OLS

Finiture - finishes
OLS - CCS



DI MANO IN MANO

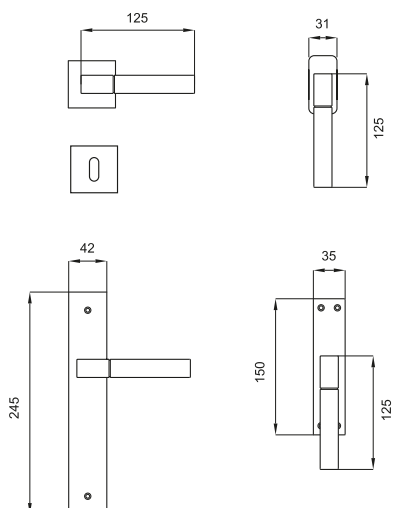

EB10
maniglia su placca Quadra
door handle on Quadra plate

EB18
maniglia su rosetta e bocchetta quadra 52 mm
door handle on square rose and escutcheon 52 mm

EB19
maniglia su rosetta R034 e bocchetta B041 quadra
50 mm base nylon
*door handle on R034 square rose and B041 escutcheon
50 mm - nylon base*

EB23
cremonese con meccanismo
window handle with mechanism

EB24
martellina q.7 senza meccanismo
window handle 7 mm square without mechanism

EB25
martellina DK quadro
square DK window handle

FINITURE / FINISHES

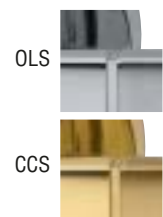





EDRA

MANIGLIONI PER ALZANTE SCORREVOLE
PULL HANDLES FOR LIFT SLIDING SYSTEM

Design: Mauro Ronchi

Fanno parte della collezione EDRA i maniglioni per alzante scorrevole con movimento brevettato. Semplici nel design e nella forma si caratterizzano per lo stile e la linearità. Un nuovo progetto che va ad arricchire il programma dnd.

The pull handles for lift sliding system with patented mechanism belong to EDRA collection. Essential design and simple shape they are characterized for their style and linearity. A new project that goes to enrich the dnd assortment.



modello depositato

Design: Mauro Ronchi

ottone stampato a caldo
hot stamped brass

EDRA



Finiture - finishes

OLV - OS - OC - OCS
ONS - PVD - PVD INOX

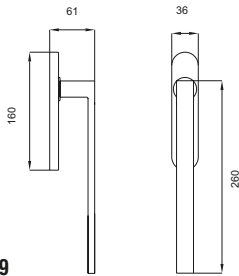

ED49

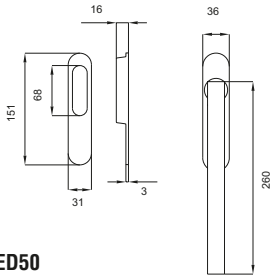

ED50

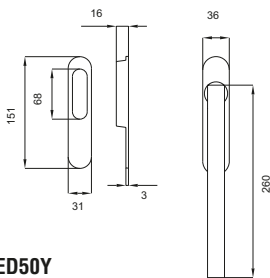

ED50Y

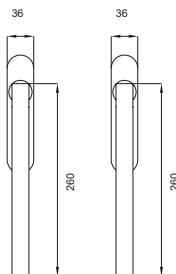

ED51

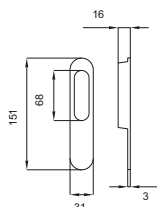

1122

ED49
maniglione singolo 260 mm placca cieca senza placchetta da incasso
pull handle 260 mm on blind hole plate without sliding door handle

ED50
maniglione singolo 260 mm placca cieca con placchetta da incasso
pull handle 260 mm on blind hole plate with sliding door handle

ED50Y
maniglione singolo 260 mm placca f.yale con placchetta da incasso
pull handle 260 mm on Euro profile hole plate with sliding door handle

ED51
maniglione accoppiato 260 m con placca f.yale
pull handle set 260 mm on Euro profile hole plate

1122
placchetta incasso singola
sliding door handle



EDRA CORTO

ottone stampato a caldo
hot stamped brass



Finiture - finishes

OLV - OS - OC - OCS
ONS - PVD - PVD INOX

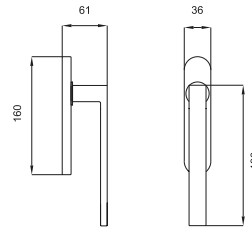

ED52

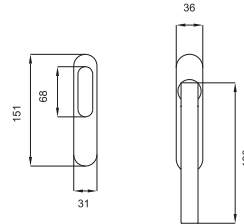

ED53

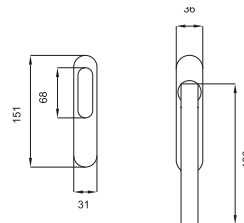

ED53Y

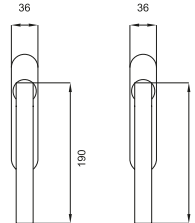

ED54

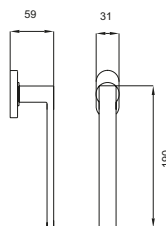

ED55

ED52
maniglione singolo 190 mm placca cieca senza placchetta da incasso
pull handle 190 mm on blind hole plate without sliding door handle

ED53
maniglione singolo 190 mm placca cieca con placchetta da incasso
pull handle 190 mm on blind hole plate with sliding door handle

ED53Y
maniglione singolo 190 mm placca f.yale con placchetta da incasso
pull handle 190 mm on Euro profile hole plate with sliding door handle

ED54
maniglione accoppiato 190 mm con placca f.yale
pull handle set 190 mm on Euro profile hole plate

ED55
maniglione 190 mm con movimento DK
DK pull handle 190 mm with mechanism

modello depositato

Design: Mauro Ronchi

ottone stampato a caldo
hot stamped brass

EDRA 02



Finiture - finishes

OLV - OS - OC - OCS

ONS - PVD - PVD INOX

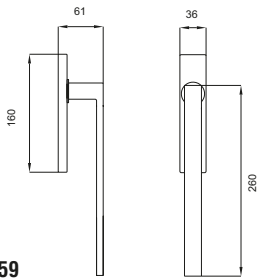

ED59

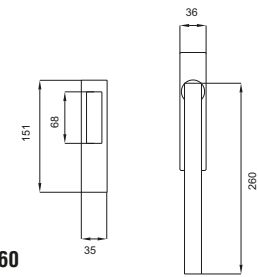

ED60

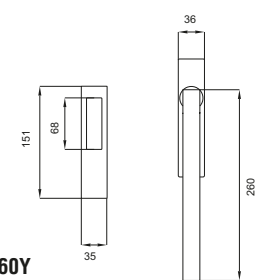

ED60Y

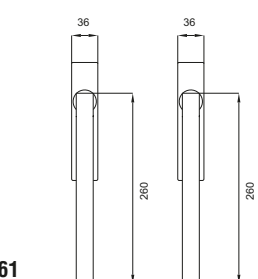

ED61

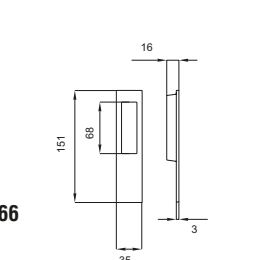

ED66

ED59

maniglione singolo 260 mm placca cieca senza placchetta da incasso
pull handle 260 mm on blind hole plate without sliding door handle

ED60

maniglione singolo 260 mm placca cieca con placchetta da incasso
pull handle 260 mm on blind hole plate with sliding door handle

ED60Y

maniglione singolo 260 mm placca f.yale con placchetta da incasso
pull handle 260 mm on Euro profile hole plate with sliding door handle

ED61

maniglione accoppiato 260 mm con placca f.yale
pull handle set 260 mm on Euro profile hole plate

ED66

placchetta incasso singola
sliding door handle



EDRA 02 CORTO

ottone stampato a caldo
hot stamped brass



Finiture - finishes

OLV - OS - OC - OCS

ONS - PVD - PVD INOX

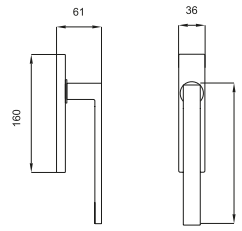

ED62

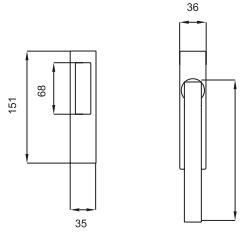

ED63

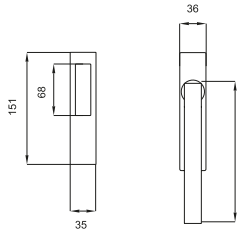

ED63Y

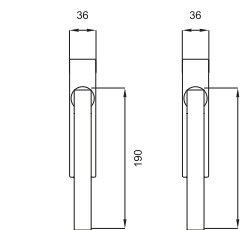

ED64

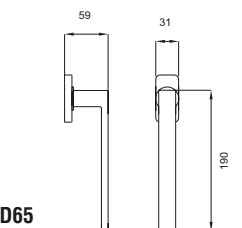

ED65

ED62

maniglione singolo 190 mm placca cieca senza placchetta da incasso
pull handle 190 mm on blind hole plate without sliding door handle

ED63

maniglione singolo 190 mm placca cieca con placchetta da incasso
pull handle 190 mm on blind hole plate with sliding door handle

ED63Y

maniglione singolo 190 mm placca f.yale con placchetta da incasso
pull handle 190 mm on Euro profile hole plate with sliding door handle

ED64

maniglione accoppiato 190 mm con placca f.yale
pull handle set 190 mm on Euro profile hole plate

ED65

maniglione 190 mm con movimento DK
DK pull handle 190 mm with mechanism



DI MANO IN MANO

modello depositato

Design: Mauro Ronchi

ottone stampato a caldo
hot stamped brass

EDRA-B



Finiture - finishes
OLS -CCS

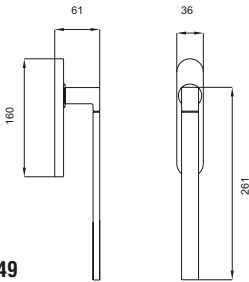

EB49

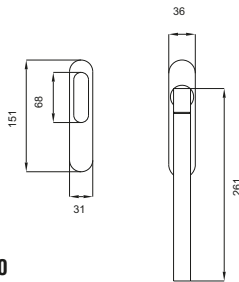

EB50

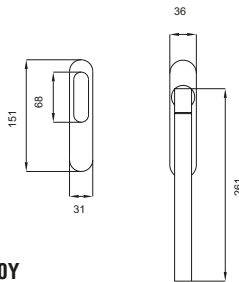

EB50Y

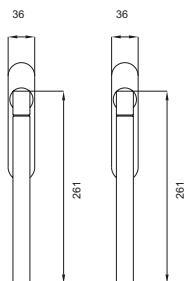

EB51

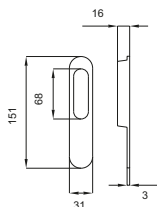

1122

EB49
maniglione singolo 260 mm placca cieca senza placchetta da incasso
pull handle 260 mm on blind hole plate without sliding door handle

EB50
maniglione singolo 260 mm placca cieca con placchetta da incasso
pull handle 260 mm on blind hole plate with sliding door handle

EB50Y
maniglione singolo 260 mm placca f.yale con placchetta da incasso
pull handle 260 mm on Euro profile hole plate with sliding door handle

EB51
maniglione accoppiato 260 mm con placca f.yale
pull handle set 260 mm on Euro profile hole plate

1122
placchetta incasso singola
sliding door handle



EDRA-B CORTO

ottone stampato a caldo
hot stamped brass



Finiture - finishes
OLS -CCS

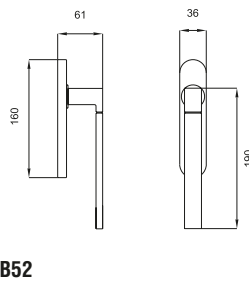

EB52

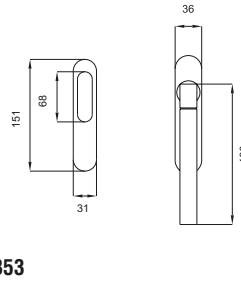

EB53

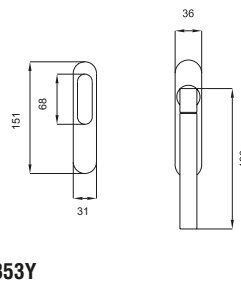

EB53Y

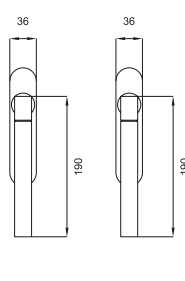

EB54

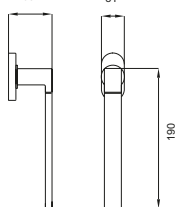

EB55

EB52
maniglione singolo 190 mm placca cieca senza placchetta da incasso
pull handle 190 mm on blind hole plate without sliding door handle

EB53
maniglione singolo 190 mm placca cieca con placchetta da incasso
pull handle 190 mm on blind hole plate with sliding door handle

EB53Y
maniglione singolo 190 mm placca f.yale con placchetta da incasso
pull handle 190 mm on Euro profile hole plate with sliding door handle

EB54
maniglione accoppiato 190 mm con placca f.yale
pull handle set 190 mm on Euro profile hole plate

EB55
maniglione 190 mm con movimento DK
DK pull handle 190 mm with mechanism



DI MANO IN MANO

modello depositato

Design: Mauro Ronchi

ottone stampato a caldo
hot stamped brass

EDRA-B 02



Finiture - finishes
OLS -CCS

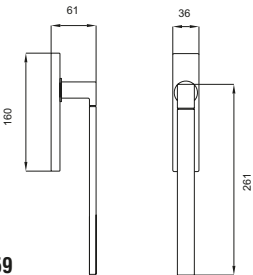

EB59

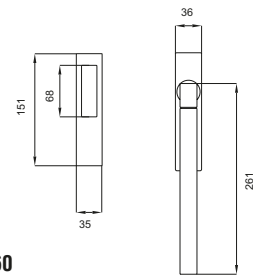

EB60

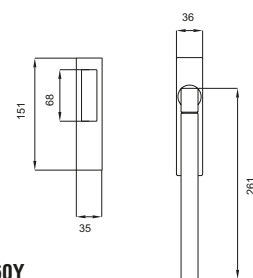

EB60Y

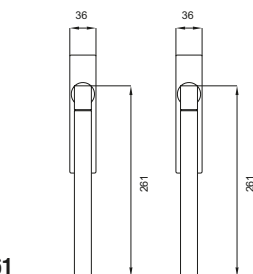

EB61

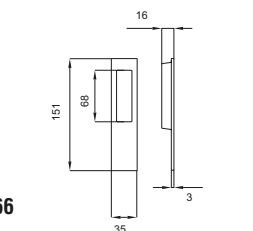

ED66

EB59
maniglione singolo 260 mm placca cieca senza placchetta da incasso
pull handle 260 mm on blind hole plate without sliding door handle

EB60
maniglione singolo 260 mm placca cieca con placchetta da incasso
pull handle 260 mm on blind hole plate with sliding door handle

EB60Y
maniglione singolo 260 mm placca f.yale con placchetta da incasso
pull handle 260 mm on Euro profile hole plate with sliding door handle

EB61
maniglione accoppiato 260 mm con placca f.yale
pull handle set 260 mm on Euro profile hole plate

ED66
placchetta incasso singola
sliding door handle



EDRA-B 02 CORTO

ottone stampato a caldo
hot stamped brass



Finiture - finishes
OLS -CCS

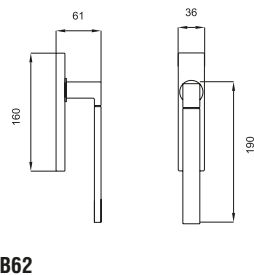

EB62

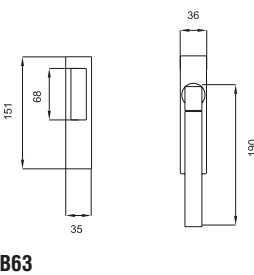

EB63

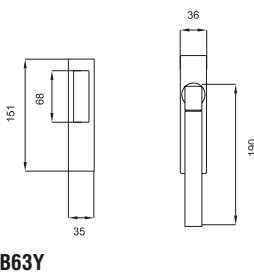

EB63Y

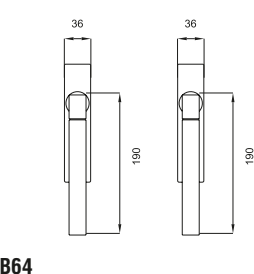

EB64

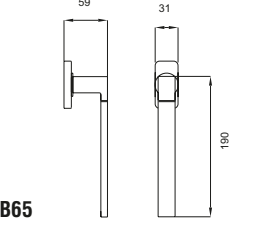

EB65

EB62
maniglione singolo 190 mm placca cieca senza placchetta da incasso
pull handle 190 mm on blind hole plate without sliding door handle

EB63
maniglione singolo 190 mm placca cieca con placchetta da incasso
pull handle 190 mm on blind hole plate with sliding door handle

EB63Y
maniglione singolo 190 mm placca f.yale con placchetta da incasso
pull handle 190 mm on Euro profile hole plate with sliding door handle

EB64
maniglione accoppiato 190 mm con placca f.yale
pull handle set 190 mm on Euro profile hole plate

EB65
maniglione 190 mm con movimento DK
DK pull handle 190 mm with mechanism



DI MANO IN MANO





FLUKE

MANIGLIONE - PULL HANDLE

Design: Karim Rashid

La forma affusolata e plastica che tanto ha contraddistinto la serie di maniglie Fluke si fa interprete di un nuovo progetto che nobilita la porta e qualifica l'habitat. La sezione circolare del maniglione si assottiglia verso il centro per poi allargarsi nuovamente, presentando un profilo diverso a seconda del punto in cui si posa lo sguardo.

The tapering and plastic shape that countersigns the Fluke handle, interprets now a new project in order to ennoble the door and the habitat. The circular section of the pull handle grows thin toward the centre then widens again creating a different profile depending on the point of view.



FLUKE MANIGLIONE

ottone stampato a caldo
hot stamped brass



Design: Karim Rashid



DI MANO IN MANO

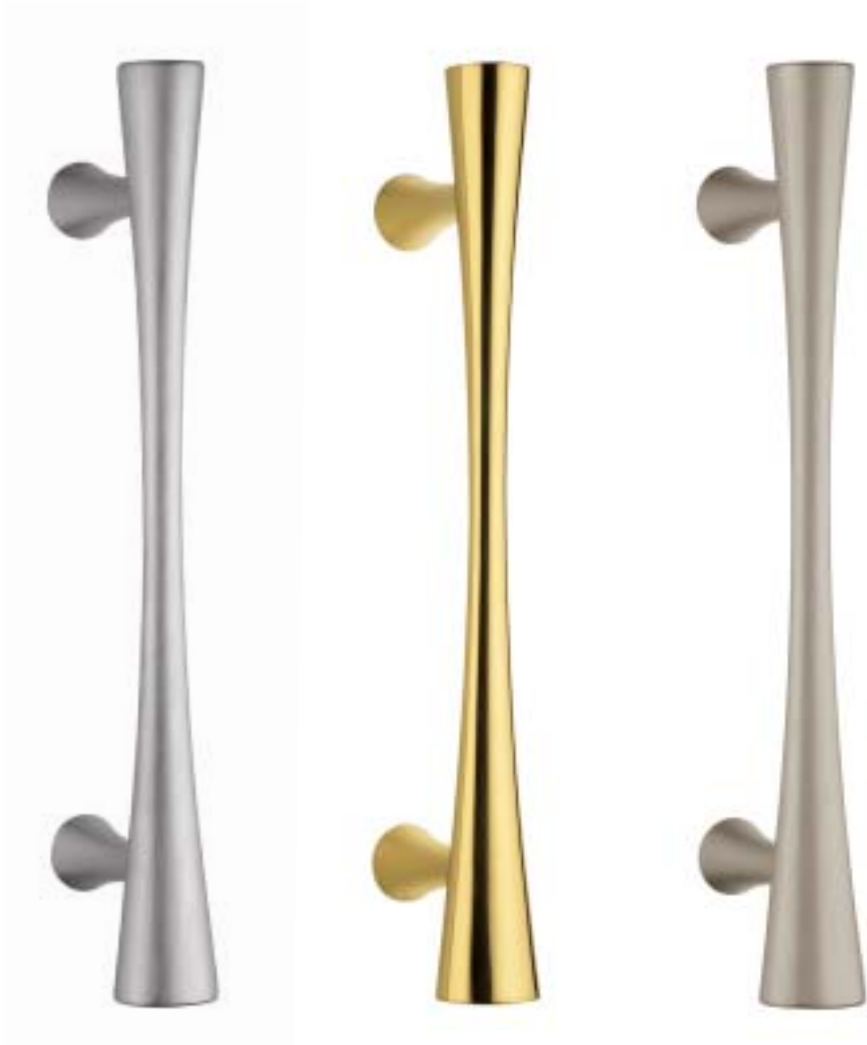

Finiture - finishes

OLV - OS - OC - OCS - ONS - PVD - PVD INOX

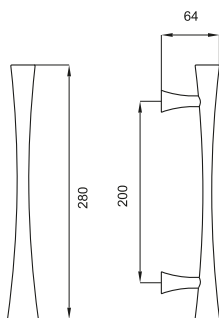

FK 27
maniglione singolo
pull handle

FINITURE / FINISHES

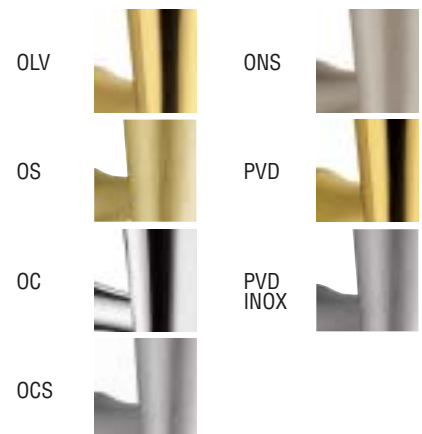

FLUKE MANIGLIONE

ottone stampato a caldo
hot stamped brass



Design: Karim Rashid



DI MANO IN MANO

Finiture - finishes

OLV - OS - OC - OCS - ONS - PVD - PVD INOX

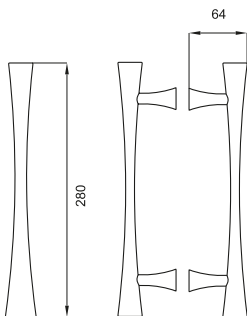

FK 28
maniglione accoppiato
pull handle set

FINITURE / FINISHES

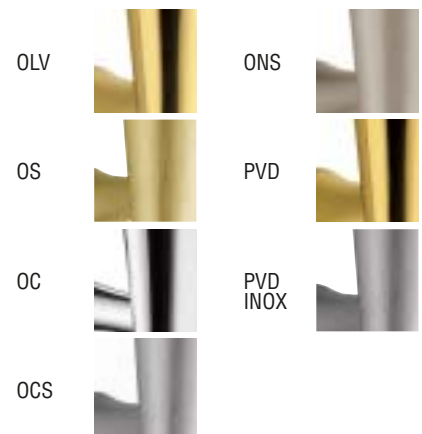





BATTENTI

DOOR KNOCKERS

Design: Mauro Ronchi

Dalle forme primarie del cerchio e del quadrato nascono i battenti RONDO' e RING. Un'evoluzione del classico battente rivisto in chiave moderna e minimalista, la linearità e la semplicità delle linee ne contraddistinguono il design. Progetto di Mauro Ronchi che continua nella ricerca minimale di oggetti destinati a rimanere nel tempo.

From the circle and the square comes up two new door knockers, RONDO' and RING. The classical knocker evolves in a new modern and minimalist style, where simplicity and linearity mark the essential design. Work signed by Mauro Ronchi who continue the research of evergreen objects.

RONDO

ottone - solid brass



Design: Mauro Ronchi



DI MANO IN MANO

Finiture - finishes

OLV - OS - AF - OC - OCS - ONS

PVD - PVD INOX

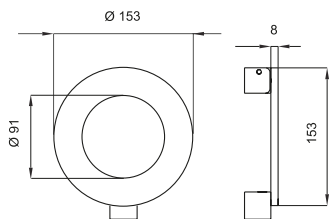

R080

battente RONDO' $\varnothing 153$ mm

RONDO' door knocker $\varnothing 153$ mm

FINITURE / FINISHES

OLV



ONS



OS



PVD



OC



PVD
INOX



OCS



RING

ottone - solid brass



Design: Mauro Ronchi



DI MANO IN MANO

Finiture - finishes
OLV - OS - AF - OC - OCS - ONS
PVD - PVD INOX

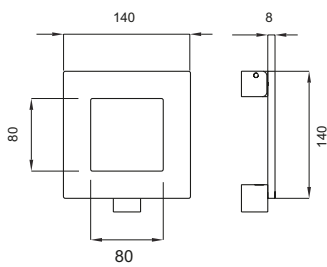

R180
battente RING 140 x 140 mm
RING door knocker 140 x 140 mm

FINITURE / FINISHES

OLV



OS



OC



OCS



ONS



PVD



PVD
INOX







ARTICOLI VARI

DOOR HANDLES



FERMAPORTA - DOOR STOP

ottone - solid brass



DI MANO IN MANO

Finiture - finishes
OLV - OS - AF - OC - OCS - ONS
PVD - PVD INOX

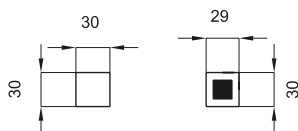

R1200
fermaporta RING
RING door stop

FINITURE / FINISHES

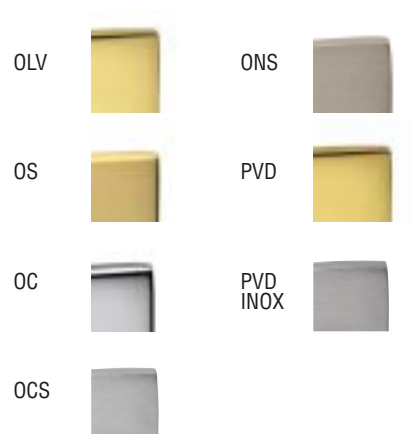

ACCESSORI PER SCORREVOLI - SLIDING DOOR HANDLES

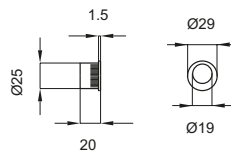

2191
frontale per scorrevole
Sliding door flush pull hole

DI MANO IN MANO

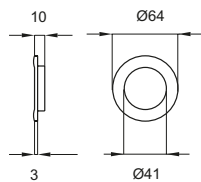

SD200
rosetta incasso RONDO'
RONDO' sliding door handle

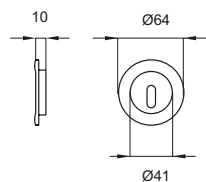

SD201
rosetta incasso RONDO' foro chiave
RONDO' sliding door handle with key hole

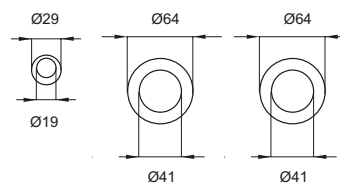

SD202
set rosette incasso RONDO' con frontale
RONDO' sliding door handle set with flush pull hole

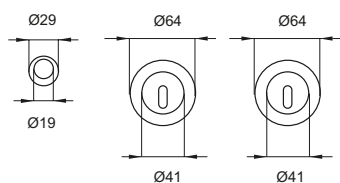

SD203
set rosette incasso RONDO' foro chiave
con frontale
RONDO' sliding door handle set key hole with flush pull hole

ACCESSORI PER SCORREVOLI - SLIDING DOOR HANDLES

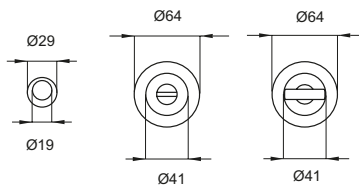
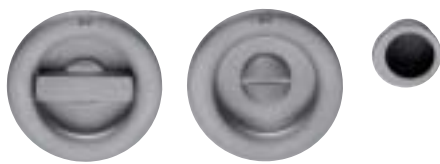

SD204

set rosette incasso RONDO' con nottolino q.8 mm con frontale
RONDO' sliding door handle set with thurn and release 8mm square spindle with flush pull hole

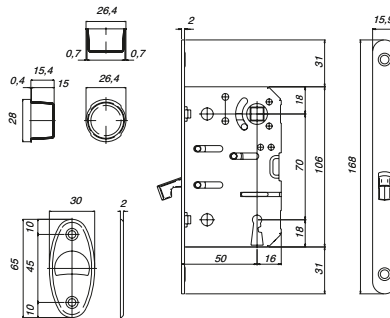

SD205

set rosette incasso RONDO' foro chiave con frontale + serratura
RONDO' sliding door handle set key hole with flush pull hole + lock

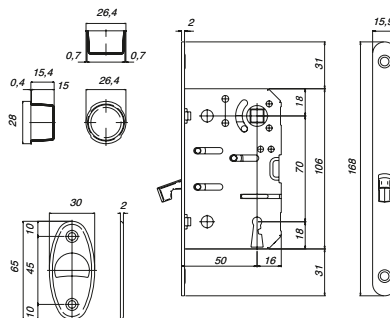
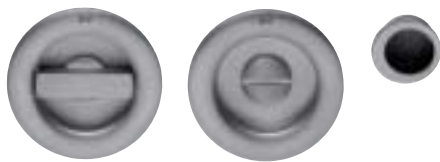

SD206

set rosette incasso RONDO' con nottolino q.8 mm con frontale + serratura*
 *possibilità di ulteriore chiusura con chiave-con l'aggiunta di due rosette SD201
*RONDO' sliding door handle set with thurn and release 8 mm sq.spindle with flush pull hole + lock**
 *possibility of further closing with key-with the addition of two roses SD201



DI MANO IN MANO

ACCESSORI PER SCORREVOLI - SLIDING DOOR HANDLES

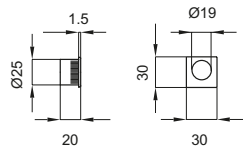

2189

frontale quadro per scorrevole
square sliding door flush pull hole

DI MANO IN MANO

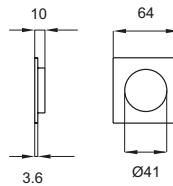

SD220

rosetta incasso RING
RING sliding door handle

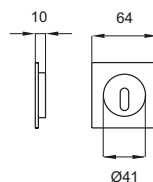

SD221

rosetta incasso RING foro chiave
RING sliding door handle with key hole

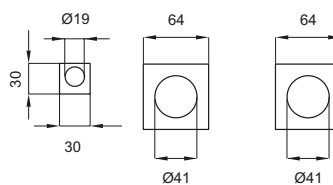
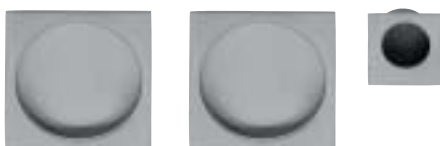

SD222

set rosette incasso RING con frontale
RING sliding door handle set with flush pull hole

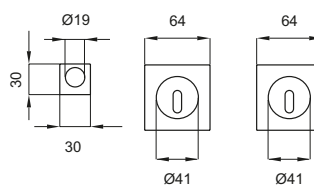

SD223

set rosette incasso RING foro chiave con frontale
RING sliding door handle set key hole with flush pull hole

ACCESSORI PER SCORREVOLI - SLIDING DOOR HANDLES

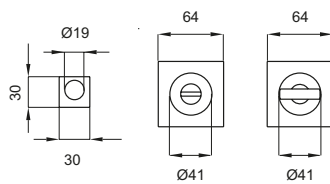

SD224

set rosette incasso RING con nottolino q.8 mm con frontale

RING sliding door handle set with thurn and release 8mm square spindle with flush pull hole

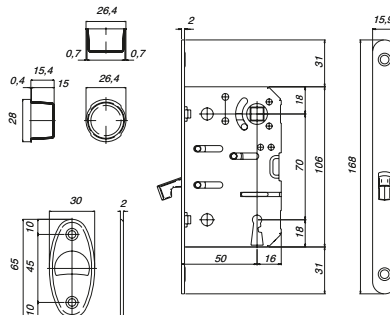

SD225

set rosette incasso RING foro chiave con frontale + serratura

RING sliding door handle set key hole with flush pull hole + lock

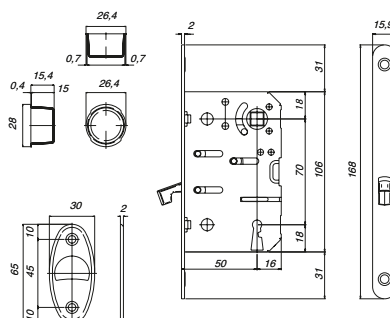

SD226

set rosette incasso RING con nottolino q.8 mm con frontale + serratura*

**possibilità di ulteriore chiusura con chiave-con l'aggiunta di due rosette SD221*

*RING sliding door handle set with thurn and release 8 mm sq.spindle with flush pull hole + lock**

**possibility of further closing with key-with the addition of two roses SD221*



DI MANO IN MANO

ROSETTE - ROSES



R016
 rosetta ny 30x60 mm per maniglie
 con molla
*rose ny 30x60 mm for handles spring
 loaded*



R023
 rosetta rettangolare ny 30x60 mm
 per maniglie con molla
*rectangular rose ny 30x60 mm
 for handles springloaded*



R032

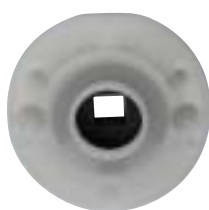

AROS#520M809RA1

R032
 rosetta 52 mm con base in nylon
 AROS#520M809RA1
*rose 52 mm with nylon base
 AROS#520M809RA1*

AROS#520M809RA1
 base in nylon 52mm con molla
 per rosetta R032
*nylon base 52mm with spring
 for R032 rose*



R034



AROS#QUAM80PRA1

R034
 rosetta quadra 50mm con base nylon
 AROS#QUAM80PRA1
*square rose 50mm with nylon base
 AROS#QUAM80PRA1*

AROS#QUAM80PRA1
 Base in nylon 50mm con molla
 per rosetta R034
*nylon base 50mm with spring
 for R034 rose*

DI MANO IN MANO

BOCCHETTE - ESCUTCHEON



B016

bocchetta 30x60 mm base nylon
escutcheon 30x60 mm with nylon base

B016P = Patent - Standard profile

B016Y = Yale - Euro profile



B023

bocchetta rettangolare 30x60 mm
base nylon
rectangular escutcheon 30x60 mm
nylon base

B023P = Patent - Standard profile

B023Y = Yale - Euro profile



DI MANO IN MANO



B027P



B027B



B027Y

B027

bocchetta 52 mm base nylon
escutcheon 52 mm with nylon base

B027P = foro Patent - Standard profile

B027B = foro BB - Standard profile

B027Y = foro Yale - Euro profile

B027PB = foro Patent con bussole
Standard profile with bushes

B027BB = foro BB con bussole
Standard profile with bushes

B027YB = foro Yale con bussole
Euro profile with bushes



B041P



B041Y

B041

bocchetta quadra 50 mm base nylon
square escutcheon 50 mm nylon base

B041P = Patent - standard profile

B041Y = Yale - Euro profile

FINISHES

Brass material finishes

OLV	Polished brass lacquered
OS	Satin brass lacquered
OLS	Polished brass + satin brass lacquered
OC	Polished chrome
OCS	Satin chrome
CCS	Polished chrome + satin chrome
CNS	Polished chrome + satin nickel lacquered
ONS	Satin nickel lacquered
NNS	Polished nickel + satin nickel lacquered
OBN	White lacquered brass
ONO	black lacquered brass
ORO	Gold plated 24K
PVD	Stainless Brass® brass colour
PVD INOX	Stainless Brass® steel colour



Stainless brass®

OC + K1	Polished chrome + LIME COLOR
OC + K2	Polished chrome + FUCHSIA COLOR
OC + K3	Polished chrome + LILAC COLOR
OC + AT	Polished chrome + ANTHRACITE COLOR

Brass & wood finishes

LPA	Polished brass + palisander wood
CPA	Polished chrome + palisander wood
TPA	Satin chrome + palisander wood
NPA	Satin nickel + palisander wood
LNO	Polished brass + american walnut wood
CNO	Polished chrome + american walnut wood
TNO	Satin chrome + american walnut wood
NNO	Satin nickel + american walnut wood

ESA range finishes

material: aluminium and zamac

CCS	Polished chrome + satin chrome
CNE	Polished chrome + black color
CBI	Polished chrome + white color

CHANGE range finishes

material: brass + insert PBT 3D image

INS01	ruled wood	INS08	leaf cream color
INS02	colored lines	INS09	leaf blu color
INS03	black and white lines	INS10	flower cream color
INS04	chequered optical color	INS11	flower pink color
INS05	chequered material color	INS12	red rose color
INS06	pie de poule color	INS13	leaf green color
INS07	chequered black and white color	INS14	flow blue color

BLIP range finishes

material: aluminium

AC	Polished chrome
ACS	Satin chrome
ANS	Satin nickel
K1	LIME COLOR
K2	FUCHSIA COLOR
K3	LILAC COLOR
AT	ANTHRACITE COLOR
PVD	Stainless Brass®
PVD INOX	Stainless Brass® steel finish



Stainless brass®

HAVANA range of finishes

material: brass + first quality leather

OLV + PA	Polished brass + Papaya
OCS + PA	Satin chrome + Papaya
OC + NA	Polished chrome + Navy
OCS + NA	Satin chrome + Navy
OC + PO	Polished chrome + Pomerol
OCS + PO	Satin chrome + Pomerol

FINISHES SPECIFICATIONS AND TESTS

Finishes	Product	Process	Covering thickness in micron	Test procedures	RESULTS
OLV - OS - OLS ONS (test made on the lacquer)	Transparent bright alkyd melamine lacquer	Electrostatic automatic. Stoving at 170°	20 ÷ 25	100 wipes with acetone Dipping in acetone for 24 hours Dipping in ethyl alcohol at 95° for 24 hours Dipping in aqueous solution of sodium hypochlorite at 5% for 24 hours Dipping in aqueous solution of acetic acid at 10% for 24 hours Corrosion test in salt spray according to the ISO 9227 ASTM B117 DIN 50021 standards up to 420 hours* Adhesion test - by a ribbon pull on 2 square centimeters (2x2)	no change light and temporary softening light and temporary softening no change no change no change no change no lacquer detachment
OC - OCS - CCS	Chrome: Bayer chromic acid Nickel: inco rounds electrolytic nickel	Galvanic	Chrome 0,10 ÷ 0,15 Nickel: 2,00 ÷ 2,10	Corrosion test in salt spray according to the ISO 9227 ASTM B117 DIN 50021 standards up to 700 hours*	no change
ONS - NNS - CNS	Nickel + lacquering	Galvanic + Electrostatic automatic. Stoving at 170°	Nickel: 2,00 ÷ 2,10 Lacquer: 20 ÷ 25	See the lacquer tests	no change
ORO	Nickel: inco rounds electrolytic nickel + 24K Gold plating	Galvanic	Nickel: 2,00 ÷ 2,10 Gold: 0,05	See the lacquer tests	no change
PVD Stainless Brass®	Zirconium or Titanium combined with reactive gas	Metallic coating known as Physical Vapor Deposition		Corrosion test in salt spray according to the ISO 9227 ASTM B117 DIN 50021 standards up to 1500 hours*	no change
PVD INOX Stainless Brass®	Zirconium or Titanium combined with reactive gas	Metallic coating known as Physical Vapor Deposition		Corrosion test in salt spray according to the ISO 9227 ASTM B117 DIN 50021 standards up to 1500 hours*	no change
				Mechanical components wear and tear test Opening/closing simulation (DM 236/89) - over 800.000 cycles	no change

* 80 hours in salt spray correspond to 1 years use (in normal use conditions)

The corrosion test in salt spray is the most critical test of those we have indicated above

FINITURE

Finiture su ottone

OLV	Ottone lucido verniciato
OS	Ottone satinato verniciato
OLS	Ottone lucido + ottone satinato verniciato
OC	Ottone cromo lucido
OCS	Ottone cromo satinato
CCS	Ottone cromo lucido + cromo satinato
CNS	Ottone cromo lucido + nickel satinato verniciato
ONS	Ottone nickel satinato verniciato
NNS	Ottone nickel lucido + nickel satinato verniciato
OBN	Ottone verniciato bianco
ONO	Ottone verniciato nero
ORO	Ottone placcato oro 24K
PVD	PVD colore ottone Stainless Brass®
PVD INOX	PVD colore acciaio Stainless Brass®



OC + K1	Ottone cromo lucido + Colore "LIME"
OC + K2	Ottone cromo lucido + Colore "FUCSIA"
OC + K3	Ottone cromo lucido + Colore "LILLA"
OC + AT	Ottone cromo lucido + Colore "ANTRACITE"

Finiture su ottone con legno

LPA	Ottone lucido + palissandro
CPA	Ottone cromo lucido + palissandro
TPA	Ottone cromo satinato + palissandro
NPA	Ottone nickel satinato + palissandro
LNO	Ottone lucido + noce americana
CNO	Ottone cromo lucido + noce americana
TNO	Ottone cromo satinato + noce americana
NNO	Ottone nickel satinato + noce americana

Finiture serie ESA

materiale: alluminio e zama

CCS	Cromo lucido + cromo satinato
CNE	Cromo + colore nero
CBI	Cromo + colore bianco

Finiture serie CHANGE

materiale: ottone + inserto PBT 3D image

INS01	legno rigato	INS08	foglia crema
INS02	righe colorate	INS09	foglia blu
INS03	righe bianco/nero	INS10	fiore crema
INS04	quadro optical	INS11	fiori rosa
INS05	quadro tessuto	INS12	rosa rossa
INS06	ped de poule	INS13	foglia verde
INS07	quadro bianco e nero	INS14	flusso blu

Finiture serie BLIP

materiale: alluminio

AC	Cromo lucido
ACS	Cromo satinato
ANS	Nickel satinato
K1	Colore "LIME"
K2	Colore "FUCSIA"
K3	Colore "LILLA"
AT	Colore "ANTRACITE"
PVD	PVD colore ottone Stainless Brass®
PVD INOX	PVD colore acciaio Stainless Brass®



Finiture serie HAVANA

materiale: ottone + pelle di prima qualità "PIENO FIORE"

OLV + PA	Ottone lucido + Papaya
OCS + PA	Ottone cromo satinato + Papaya
OC + NA	Ottone cromo lucido + Navy
OCS + NA	Ottone cromo satinato + Navy
OC + PO	Ottone cromo lucido + Pomerol
OCS + PO	Ottone cromo satinato + Pomerol

CARATTERISTICHE E TEST DELLE FINITURE

FINITURE	PRODOTTO	PROCESSO	SPESSORE MICRON	TEST	RISULTATO
OLV - OS - OLS ONS (su vernice)	Vernice trasparente lucida alchidica melaminica	Elettrostatico automatico. Cottura a 170°	20 ÷ 25	100 passaggi con acetone Immersione in acetone per 24 ore Immersione in alcool etilico a 95° per 24 ore Immersione in soluzione acquosa di ipoclorito di sodio al 5% per 24 ore Immersione in soluzione acquosa di acido acetico al 10% per 24 ore Prova di resistenza alla corrosione in nebbia salina come da norme ISO 9227 ASTM B117 DIN 50021 fino a 420 ore* Prova di aggrappaggio mediante strappo su quadratura di 2 cm²	nessuna alterazione leggero e temporaneo rammollimento leggero e temporaneo rammollimento nessuna alterazione nessuna alterazione nessuna alterazione nessuna alterazione nessun distacco
OC - OCS - CCS	Cromo: acido cromico Bayer Nickel: inco rounds nickel elettrolitico	Galvanico	Cromo: 0,10 ÷ 0,15 Nickel: 2,00 ÷ 2,10	Prova di resistenza alla corrosione in nebbia salina come da norme ISO 9227 ASTM B117 DIN 50021 fino a 700 ore*	nessuna alterazione
ONS - NNS - CNS	Nickel + vernice	Galvanico + elettrostatico automatico. Cottura a 170°	Nickel: 2,00 ÷ 2,10 Vernice: 20 ÷ 25	Vedi test su vernice	nessuna alterazione
ORO	Nickel: inco rounds nickel elettrolitico + Film di ORO 24K	Galvanico	Nickel: 2,00 ÷ 2,10 Oro: 0,05	Vedi test su vernice	nessuna alterazione
PVD Stainless Brass®	Zirconio o Titanio abbinati a gas reattivi	Sottovuoto		Prova di resistenza alla corrosione in nebbia salina come da norme ISO 9227 ASTM B117 DIN 50021 fino a 1500 ore*	nessuna alterazione
PVD INOX Stainless Brass®	Zirconio o Titanio abbinati a gas reattivi	Sottovuoto		Prova di resistenza alla corrosione in nebbia salina come da norme ISO 9227 ASTM B117 DIN 50021 fino a 1500 ore*	nessuna alterazione
				TEST DI USURA MOVIMENTO MECCANICO Prova di simulazione apertura/chiusura (DM 236/89) oltre a 800.000 movimenti	nessuna usura

* 80 ore in nebbia salina = un anno di durata (in normali condizioni di utilizzo)

La prova di resistenza alla corrosione in nebbia salina è il test più determinante fra quelli sopra riportati

**ORDERS**

All direct orders as well as those received through our Agents are subject to our approval.

Orders received by telephone or verbally are only considered valid after receipt of order confirmation. Any addition to orders on which production has started are accepted with reserve and may delay the agreed delivery terms.

FMN Martinelli SpA is not responsible for mistakes in the execution of the orders if these are caused by incorrect or incomplete information received in the original order.

FMN Martinelli SpA reserves the right to bring modifications to the products, which are considered necessary, without any prior information. The technical measurements indicated in this catalogue are indicative.

DELIVERY

FMN Martinelli SpA undertakes to respect, wherever possible, the delivery date requested by the Buyer. However, all despatch dates quoted by FMN Martinelli are to be considered approximate. Any delay, missing or partial shipment do not entitle the Buyer to any claim or indemnity. All orders can also be partially shipped and we reserve the right to cancel any balances outstanding.

PRICES

All prices quoted are ex-VAT. Should any heavy increase in cost of raw material occur then we reserve the right to increase prices even before shipment of the order.

PACKING

All packing is included in the price. Box quantities are indicated in the price-list. FMN Martinelli reserve the right to increase any smaller quantities to box quantity.

If this is not acceptable to the Buyer then we may apply a surcharge of 20% to price quoted in the price list.

MINIMUM ORDER VALUE

For export orders – please contact our export department for more information.

TRANSPORT

The goods always travel at the Buyer's risk even if goods are delivered carriage paid. FMN Martinelli SpA is not responsible for delays, tamperings, burglaries or other shortcomings during the carriage.

The Buyer is bound to collect the goods and check their conformity on arrival.

In case of non-collection of the goods, we will debit the Buyer with all costs incurred plus a 20% of the goods value as re-stocking charge when the goods are returned to us.

The transport costs are always at Buyer's expense unless special terms have been agreed.

CLAIMS

Claims for shortages, damaged goods or incorrect supply must be made within 8 days from receipt of order.

In the event of goods proving faulty we will replace them or credit them but in doing so, no further liability, consequential or otherwise, is accepted. No further indemnity is due.

PAYMENT

All payments are to be made within the agreed terms and exclusively to the domicile of FMN Martinelli SpA.

In case of delayed payment interest will be charged, according to the Decree Law 231/2002, at the rates stated by the same Decree Law.

RESERVE OF OWNERSHIP

All goods remain property of FMN Martinelli SpA until they are paid for in full.

All goods remain of our ownership even if passed to a third party, distrained or acquired by bankruptcy.

All proceeds from a sale even forced will be passed to FMN Martinelli SpA until the complete clearance of the credit.

JURISDICTION:

For any dispute, the jurisdiction is the Law Court of Brescia, Italy.

**ORDINI**

Tutti gli ordini ricevuti direttamente o tramite nostri Agenti sono subordinati all'accettazione della Casa.

Gli ordini telefonici o verbali sono considerati validi dopo il ricevimento della conferma d'ordine.

Eventuali aggiunte agli ordini già in corso vengono accettate con riserva e possono ritardare il termine di consegna concordato.

La FMN Martinelli SPA non è ritenuta responsabile di errori nell'evasione degli ordini se questi sono causati da errata o incompleta indicazione nell'ordine.

La FMN Martinelli SPA si riserva il diritto di apportare modifiche ai prodotti, ritenute necessarie, senza preavviso alcuno. Le misure tecniche indicate nel presente catalogo sono indicative.

CONSEGNA

La FMN Martinelli SPA si impegna a rispettare il più fedelmente possibile la data di consegna richiesta dal Committente. La data di consegna stabilita ha comunque solo carattere indicativo. Eventuali ritardi e la mancata o parziale consegna non comportano richieste di indennizzo. Gli ordini possono essere evasi anche parzialmente con riserva da parte della Casa di annullare la rimanenza.

PREZZI

I prezzi esposti nel listino si intendono in Euro IVA esclusa, resa franco nostra fabbrica. Gli stessi possono essere aumentati anche prima dell'evasione dell'ordine se nel frattempo intervengono forti variazioni sul costo della materia prima.

IMBALLI

Gli imballi sono compresi nel prezzo. Le quantità sono indicate nel listino. Per ordini di quantità inferiore la FMN Martinelli SPA si riserva di aumentarla fino a raggiungere il quantitativo della confezione. Per richieste di quantitativi inferiori viene applicata una maggiorazione del 20% sul prezzo di listino.

VALORE MINIMO D'ORDINE

Non si effettuano spedizioni con valore merce inferiore a Euro 250,00 netto.

TRASPORTO

La merce viaggia sempre ad esclusivo rischio del Committente, anche se resa franco destino. La FMN Martinelli SPA non è responsabile per ritardi, manomissioni, furti o altre mancanze avvenute durante il trasporto.

Il Committente ha l'obbligo di ritirare la merce e verificarne la conformità al momento della consegna. In caso di mancato ritiro vengono o addebitate tutte le spese sostenute oltre ad una ritenuta del 20% sul valore della merce ritornata in perfetto stato.

Le spese di trasporto sono sempre a carico del Committente, salvo particolari accordi.

RECLAMI

Eventuali reclami devono essere fatti pervenire presso la sede della FMN Martinelli SPA entro e non oltre otto giorni dal ricevimento della merce, pena la decadenza. Per prodotti difettosi o non corrispondenti all'ordine la FMN Martinelli SPA ritirerà il materiale a proprie spese effettuandone la sostituzione o accreditandone l'importo relativo. Nessun altro risarcimento è dovuto.

PAGAMENTI

I pagamenti devono essere effettuati nei termini convenuti ed inoltrati esclusivamente al domicilio della FMN Martinelli SPA.

In caso di ritardato pagamento, la pretesa degli interessi, ai sensi del D.Lgs. 231/2002, sarà richiesta previa la messa in mora, ai tassi previsti dallo stesso decreto legislativo.

RISERVA DI PROPRIETA'

La merce fornita rimane di proprietà della FMN Martinelli SPA fino al pagamento completo della stessa. Anche nel caso in cui la merce venga rivenduta, pignorata o acquisita da procedura fallimentare o concorsuale.

Il ricavato di una vendita anche forzata andrà alla FMN Martinelli SPA fino ad esaurimento del credito.

COMPETENZA

Per qualsiasi controversia si intende competente il Foro di Brescia



dnd è un marchio di FMN Martinelli S.p.A.
località Piani di Mura 2 - 25070 Casto (BS) Italia
Tel. +39-0365-899113 r.a. Fax +39-0365-899118
www.dndmaniglie.it

Numero Verde
800020343



dnd è un marchio di FMN Martinelli S.p.A.
località Piani di Mura 2
25070 Casto (BS) Italia
Tel. +39-0365-899113 r.a. Fax +39-0365-899118

**AZIENDA CON SISTEMA DI GESTIONE
PER LA QUALITÀ CERTIFICATO DA DNV
= UNI EN ISO 9001:2008 =**